

REVISIONS				
ZONE	REV	DESCRIPTION	DATE	APPROVED
	A	ORIGINAL RELEASE	12/06	

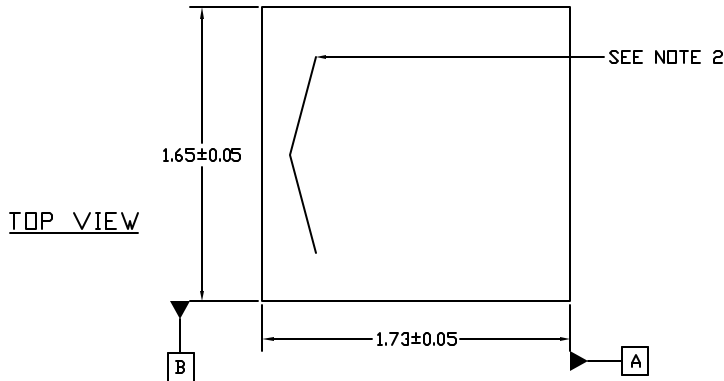
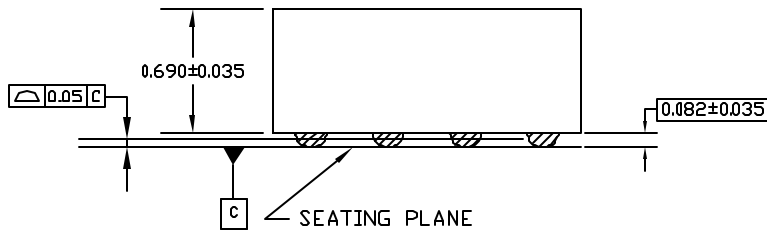
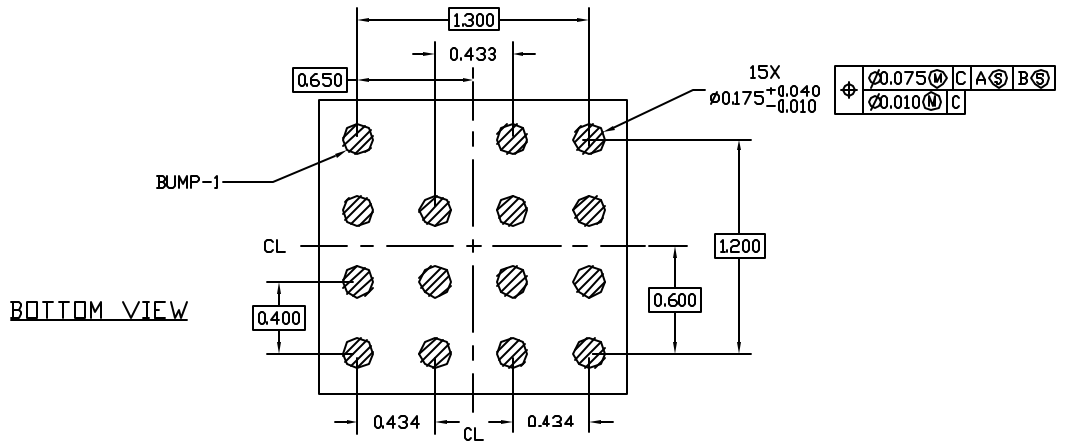

PACKAGE OUTLINE

SIGNATURE		DATE			
QA APVD:					
ENGR MGR:				DS1804X FLIP CHIP PACKAGE, 0.434MM PITCH PACKAGE CODE: BF1522-1	
ENGR BY: B. MCCARTY 8/12/1999					
CHECK BY: S. CHINNUSAMY 11/2006		SIZE A	FSCM NO.	DWG NO. 56-G7013-001	REV A
DRAWN BY: B. MCCARTY 8/2/1999		SCALE NONE		SHEET 1 / 2	

NOTES

1. DIMENSIONS: MM [INCH]
2. LASER MARK
3. SEE TABLE 1 FOR SUBSTRATE LAND PAD CONNECTIONS AND COORDINATES
4. UNDERFILL RECOMMENDED FOR FR-4 AND EQUIVALENT SUBSTRATE ASSEMBLY APPLICATIONS

TABLE 1. LAND PAD CONNECTIONS AND CENTER COORDINATES						
		MILLIMETERS			INCHES	
NUMBER	NAME	X	Y	X	Y	
1	INC	-0.65	-0.60	-0.026	-0.024	
2	U/D	-0.65	-0.20	-0.026	-0.008	
3	H	-0.65	0.20	-0.026	0.008	
4	GND	-0.65	0.60	-0.026	0.024	
5	N/C	-0.22	-0.20	-0.009	-0.008	
6	N/C	-0.22	0.20	-0.009	0.008	
7	N/C	-0.22	0.60	-0.009	0.024	
8	N/C	0.22	-0.60	0.009	-0.024	
9	N/C	0.22	-0.20	0.009	-0.008	
10	N/C	0.22	0.20	0.009	0.008	
11	N/C	0.22	0.60	0.009	0.024	
12	W	0.65	0.60	0.026	0.024	
13	L	0.65	0.20	0.026	0.008	
14	CS	0.65	-0.20	0.026	-0.008	
15	VCC	0.65	-0.60	0.026	-0.024	

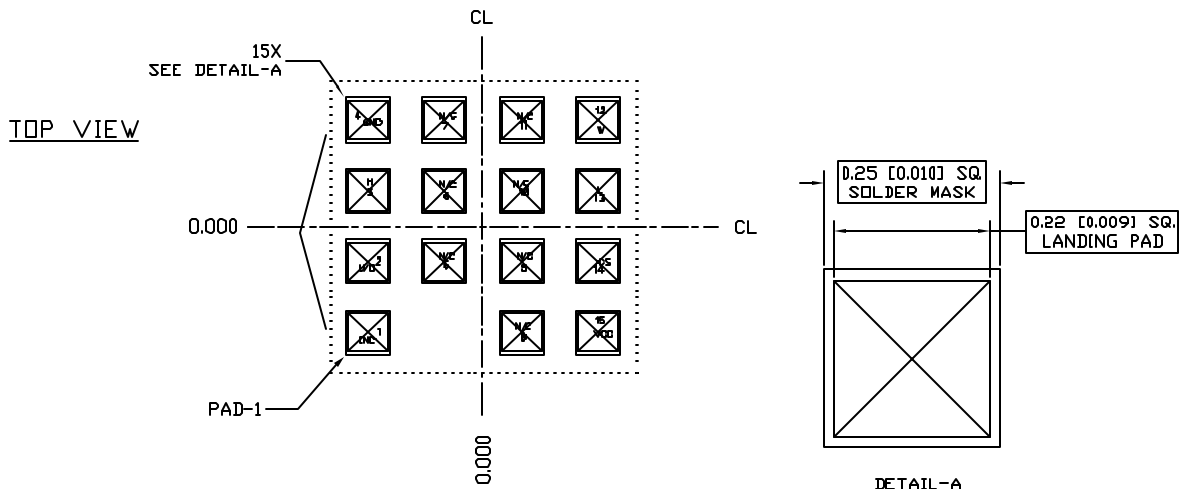

RECOMMENDED SUBSTRATE LAND PATTERN

SIZE A	FSCM NO.	DWG NO. 56-G7013-001	REV A
SCALE NONE	SHEET 2 / 2		