

	INCHES		MILLIMETERS	
	MIN	MAX	MIN	MAX
A	---	0.225	---	5.72
B	0.014	0.023	0.36	0.58
B1	0.038	0.065	0.97	1.65
C	0.008	0.015	0.20	0.38
E	0.510	0.610	12.95	15.49
E1	0.590	0.620	14.99	15.75
e	0.100		2.54	
L	0.125	0.200	3.18	5.08
Q	0.015	0.060	0.38	1.52
S	0.005	---	0.13	---
eA	0.600 BSC			
eB	0.700 BSC			

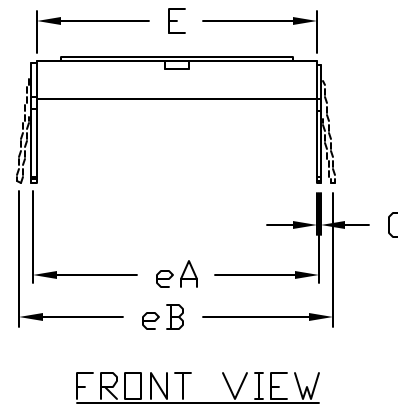
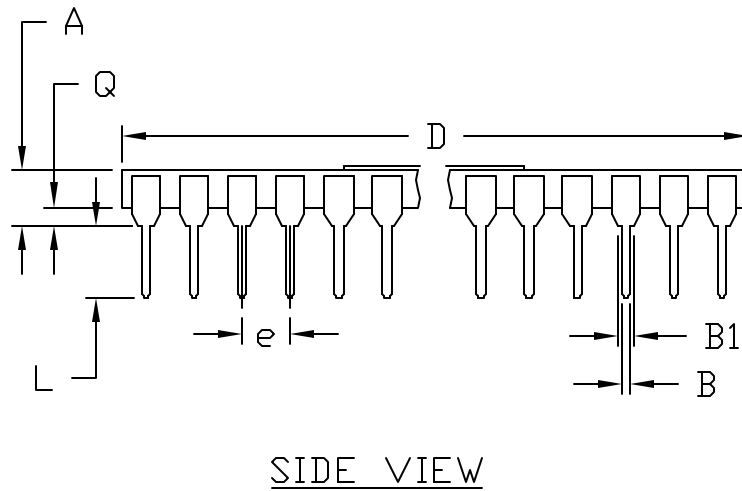

VARIATIONS TABLE

	INCHES		MILLIMETERS		N	CASE
	MIN	MAX	MIN	MAX		
D	---	1.29	---	32.77	24	J:D3
D	---	1.49	---	37.85	28	D10
D	---	2.096	---	53.24	40	Q:D5

NOTES:

1. CONTROLLING DIMENSIONS: INCH.
2. MEETS 1835 CASE OUTLINE CONFIGURATION #3 AS SHOWN IN TABLE
3. N = NUMBER OF PINS
4. NUMBER OF LEADS SHOWN ARE FOR REFERENCE ONLY.

-DRAWING NOT TO SCALE-



TITLE: PACKAGE OUTLINE, SIDE BRAZE .600"			
APPROVAL	DOCUMENT CONTROL NO. 21-0048	REV. B	1/1