



# High-Output-Drive, Precision, Low-Power, Single-Supply, Rail-to-Rail I/O Op Amps with Shutdown

## General Description

The MAX4165–MAX4169 family of operational amplifiers combines excellent DC accuracy with high output current drive, single-supply operation, and rail-to-rail inputs and outputs. These devices operate from a single +2.7V to +6.5V supply, or from dual  $\pm 1.35V$  to  $\pm 3.25V$  supplies. They typically draw 1.2mA supply current, and are guaranteed to deliver 80mA output current.

The MAX4166/MAX4168 have a shutdown mode that reduces supply current to 38 $\mu A$  per amplifier and places the outputs into a high-impedance state. The MAX4165–MAX4169's precision performance combined with high output current, wide input/output dynamic range, single-supply operation, and low power consumption makes them ideal for portable audio applications and other low-voltage, battery-powered systems. The MAX4165 is available in the space-saving 5-pin SOT23 package and the MAX4166 is available in a tiny 2mm x 2mm x 0.8mm  $\mu DFN$  package.

## Selector Guide

PART	AMPS PER PACKAGE	SHUTDOWN MODE
MAX4165	Single	—
MAX4166	Single	Yes
MAX4167	Dual	—
MAX4168	Dual	Yes
MAX4169	Quad	—

## Applications

Portable/Battery-Powered Audio Applications  
 Portable Headphone Speaker Drivers  
 Laptop/Notebook Computers  
 Sound Ports/Cards  
 Set-Top Boxes  
 Cell Phones  
 Hands-Free Car Phones (kits)  
 Signal Conditioning  
 Digital-to-Analog Converter Buffers  
 Transformer/Line Drivers  
 Motor Drivers

Typical Operating Circuit appears at end of data sheet.

## Features

- ◆ 80mA (min) Output Drive Capability
- ◆ Rail-to-Rail Input Common-Mode Voltage Range
- ◆ Rail-to-Rail Output Voltage Swing
- ◆ 1.2mA Supply Current per Amplifier
- ◆ +2.7V to +6.5V Single-Supply Operation
- ◆ 5MHz Gain-Bandwidth Product
- ◆ 250 $\mu V$  Offset Voltage
- ◆ 120dB Voltage Gain ( $R_L = 100k\Omega$ )
- ◆ 88dB Power-Supply Rejection Ratio
- ◆ No Phase Reversal for Overdriven Inputs
- ◆ Unity-Gain Stable for Capacitive Loads to 250pF
- ◆ Low-Power Shutdown Mode:  
 Reduces Supply Current to 38 $\mu A$  Places Outputs in High-Impedance State
- ◆ Available in 5-Pin SOT23 Package (MAX4165) or 2mm x 2mm x 0.8mm  $\mu DFN$  (MAX4166)

## Ordering Information

PART	TEMP RANGE	PIN-PACKAGE	TOP MARK
MAX4165EUK-T	-40°C to +85°C	5 SOT23-5	AABY
MAX4166EPA	-40°C to +85°C	8 Plastic DIP	—
MAX4166ESA	-40°C to +85°C	8 SO	—
MAX4166EUA	-40°C to +85°C	8 $\mu MAX$	—
MAX4166ELA+T	-40°C to +85°C	8 $\mu DFN$ -8	AAG

+ Denotes lead-free package.

Ordering Information continued on last page.

## Pin Configurations

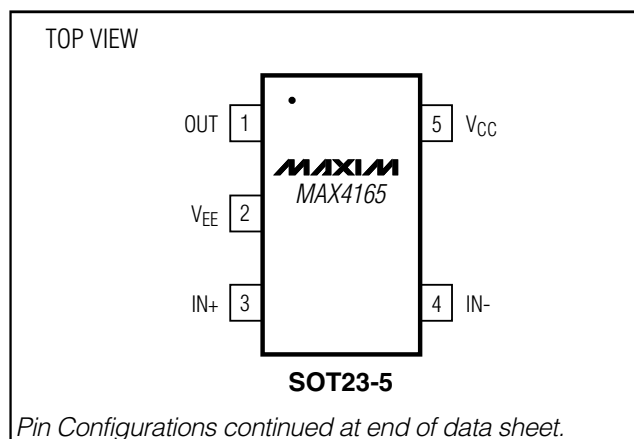

# High-Output-Drive, Precision, Low-Power, Single-Supply, Rail-to-Rail I/O Op Amps with Shutdown

## ABSOLUTE MAXIMUM RATINGS

Supply Voltage (V <sub>CC</sub> to V <sub>EE</sub> ).....7V	8-Pin $\mu$ DFN (derate 4.8mW/°C above +70°C) .....380mW
IN <sub>+</sub> , IN <sub>-</sub> , SHDN <sub>+</sub> .....(V <sub>EE</sub> - 0.3V) + (V <sub>CC</sub> + 0.3V)	10-Pin $\mu$ MAX (derate 5.60mW/°C above +70°C) .....444mW
OUT <sub>-</sub> (shutdown mode) .....(V <sub>EE</sub> - 0.3V) + (V <sub>CC</sub> + 0.3V)	14-Pin Plastic DIP (derate 10.00mW/°C above +70°C) 800mW
Output Short-Circuit Duration to V <sub>CC</sub> or V <sub>EE</sub> (Note 1) .....Continuous	14-Pin SO (derate 8.33mW/°C above +70°C).....667mW
Continuous Power Dissipation (T <sub>A</sub> = +70°C)	Operating Temperature Range .....-40°C to +85°C
5-Pin SOT23 (derate 7.10mW/°C above +70°C).....571mW	Junction Temperature.....+150°C
8-Pin Plastic DIP (derate 9.09mW/°C above +70°C) ...727mW	Storage Temperature Range.....-65°C to +150°C
8-Pin SO (derate 5.88mW/°C above +70°C).....471mW	Lead Temperature (soldering, 10s).....+300°C
8-Pin $\mu$ MAX (derate 4.10mW/°C above +70°C) .....330mW	

**Note 1:** Continuous power dissipation should also be observed.

Stresses beyond those listed under "Absolute Maximum Ratings" may cause permanent damage to the device. These are stress ratings only, and functional operation of the device at these or any other conditions beyond those indicated in the operational sections of the specifications is not implied. Exposure to absolute maximum rating conditions for extended periods may affect device reliability.

## DC ELECTRICAL CHARACTERISTICS

(V<sub>CC</sub> = +2.7V to +6.5V, V<sub>EE</sub> = 0V, V<sub>CM</sub> = 0V, V<sub>OUT</sub> = (V<sub>CC</sub> / 2), R<sub>L</sub> = 100k $\Omega$  to (V<sub>CC</sub> / 2), V<sub>SHDN</sub>  $\geq$  2V, T<sub>A</sub> = +25°C, unless otherwise noted.)

PARAMETER	SYMBOL	CONDITIONS		MIN	TYP	MAX	UNITS
Input Offset Voltage	V <sub>OS</sub>	V <sub>CM</sub> = V <sub>EE</sub> to V <sub>CC</sub>	MAX416_EPA/EPD		0.25	0.85	mV
			MAX416_ESA/ESD		0.25	0.85	
			MAX416_EUA/EUB/ELA		0.35	1.7	
			MAX416_EUK		0.35	1.5	
			MAX4169E_D		0.25	1.0	
Input Bias Current	I <sub>B</sub>	V <sub>CM</sub> = V <sub>EE</sub> to V <sub>CC</sub>		$\pm$ 50		$\pm$ 150	nA
Input Offset Current	I <sub>OS</sub>	V <sub>CM</sub> = V <sub>EE</sub> to V <sub>CC</sub>		$\pm$ 1		$\pm$ 15	nA
Differential Input Resistance	R <sub>IN(DIFF)</sub>	V <sub>IN+</sub> - V <sub>IN-</sub>   $\leq$ 1.8V		500			k $\Omega$
		V <sub>IN+</sub> - V <sub>IN-</sub>   > 1.8V		2			
Common-Mode Input Voltage Range	V <sub>CM</sub>	Inferred from CMRR test		V <sub>EE</sub> - 0.25		V <sub>CC</sub> + 0.25	V
Common-Mode Rejection Ratio	CMRR	V <sub>EE</sub> - 0.25V < V <sub>CM</sub> < (V <sub>CC</sub> + 0.25V)	MAX416_EPA/EPD	72	93		dB
			MAX416_ESA/ESD	72	93		
			MAX416_EUA/EUB/ELA	62	89		
			MAX416_EUK	63	90		
			MAX4169E_D	71	93		
Power-Supply Rejection Ratio	PSRR	V <sub>CC</sub> = 2.7V to 6.5V	MAX416_EPA/EPD	72	88		dB
			MAX416_ESA/ESD	72	88		
			MAX416_EUA/EUB/ELA	72	86		
			MAX416_EUK	72	86		
			MAX4169E_D	70	88		
Output Resistance	R <sub>OUT</sub>	A <sub>VCL</sub> = +1V/V		0.1			k $\Omega$
Off-Leakage Current in Shutdown	I <sub>OUT(SHDN)</sub>	V <sub>SHDN</sub> < 0.8V, V <sub>OUT</sub> = 0V to V <sub>CC</sub>		$\pm$ 0.001		$\pm$ 2	$\mu$ A
Large-Signal Voltage Gain	A <sub>VOL</sub>	V <sub>CC</sub> = 5V	V <sub>OUT</sub> = 0.2V to 4.8V, R <sub>L</sub> = 100k $\Omega$	95	120		dB
			V <sub>OUT</sub> = 0.6V to 4.4V, R <sub>L</sub> = 25 $\Omega$	71	83		

# High-Output-Drive, Precision, Low-Power, Single-Supply, Rail-to-Rail I/O Op Amps with Shutdown

MAX4165-MAX4169

## DC ELECTRICAL CHARACTERISTICS (continued)

( $V_{CC} = +2.7V$  to  $+6.5V$ ,  $V_{EE} = 0V$ ,  $V_{CM} = 0V$ ,  $V_{OUT} = (V_{CC} / 2)$ ,  $R_L = 100k\Omega$  to  $(V_{CC} / 2)$ ,  $V_{SHDN} \geq 2V$ ,  $T_A = +25^\circ C$ , unless otherwise noted.)

PARAMETER	SYMBOL	CONDITIONS		MIN	TYP	MAX	UNITS
Output Voltage Swing	$V_{OUT}$	$V_{CC} = 5V$	$R_L = 100k\Omega$	$V_{CC} - V_{OH}$	15	30	mV
				$V_{OL} - V_{EE}$	10	25	
			$R_L = 25\Omega$	$V_{CC} - V_{OH}$	340	430	
				$V_{OL} - V_{EE}$	160	350	
Output Source/Sink Current (Note 2)		$V_{OUT} = 0.6V$ to $(V_{CC} - 0.6V)$		$\pm 80$	$\pm 125$		mA
$\overline{SHDN}$ Logic Threshold (Note 3)	$V_{IL}$	Shutdown mode				0.8	V
	$V_{IH}$	Normal mode		2.0			
$\overline{SHDN}$ Input Bias Current		$V_{EE} < V_{SHDN} < V_{CC}$				$\pm 3.0$	$\mu A$
Operating Supply-Voltage Range	$V_{CC}$	Inferred from PSRR test		2.7		6.5	V
Quiescent Supply Current (per Amplifier)	$I_{CC}$	$V_{CC} = 5V$			1.3	1.5	mA
		$V_{CC} = 3V$			1.2	1.4	
Shutdown Supply Current (per Amplifier)	$I_{CC}(\overline{SHDN})$	$V_{SHDN} < 0.8V$	$V_{CC} = 5V$		58	75	$\mu A$
			$V_{CC} = 3V$		38	49	

## DC ELECTRICAL CHARACTERISTICS

( $V_{CC} = +2.7V$  to  $+6.5V$ ,  $V_{EE} = 0V$ ,  $V_{CM} = 0V$ ,  $V_{OUT} = (V_{CC} / 2)$ ,  $R_L = 100k\Omega$  to  $(V_{CC} / 2)$ ,  $V_{SHDN} \geq 2V$ ,  $T_A = -40^\circ C$  to  $+85^\circ C$ , unless otherwise noted.) (Note 4)

PARAMETER	SYMBOL	CONDITIONS		MIN	TYP	MAX	UNITS
Input Offset Voltage	$V_{OS}$	$V_{CM} = V_{EE}$ to $V_{CC}$	MAX416_EPA/EPD			1.0	mV
			MAX416_ESA/ESD			1.0	
			MAX416_EUA/EUB/ELA			4.9	
			MAX416_EUK			4.3	
			MAX4169E_D			1.2	
Offset-Voltage Tempco	$\Delta V_{OS}/\Delta T$				$\pm 3$		$\mu V/^\circ C$
Input Bias Current	$I_B$	$V_{CM} = V_{EE}$ to $V_{CC}$				$\pm 225$	nA
Input Offset Current	$I_{OS}$	$V_{CM} = V_{EE}$ to $V_{CC}$				$\pm 21$	nA
Common-Mode Input Voltage Range	$V_{CM}$	Inferred from CMRR test		$V_{EE} - 0.15$		$V_{CC} + 0.15$	V
Common-Mode Rejection Ratio	CMRR	$V_{EE} - 0.15V < V_{CM} < (V_{CC} + 0.15V)$	MAX416_EPA/EPD			71	dB
			MAX416_ESA/ESD			71	
			MAX416_EUA/EUB/ELA			56	
			MAX416_EUK			57	
			MAX4169E_D			69	
Power-Supply Rejection Ratio	PSRR	$V_{CC} = 2.7V$ to $6.5V$	MAX416_EPA/EPD			67	dB
			MAX416_ESA/ESD			67	
			MAX416_EUA/EUB/ELA			65	
			MAX416_EUK			65	
			MAX4169E_D			66	

# High-Output-Drive, Precision, Low-Power, Single-Supply, Rail-to-Rail I/O Op Amps with Shutdown

## DC ELECTRICAL CHARACTERISTICS (continued)

( $V_{CC} = +2.7V$  to  $+6.5V$ ,  $V_{EE} = 0V$ ,  $V_{CM} = 0V$ ,  $V_{OUT} = (V_{CC} / 2)$ ,  $R_L = 100k\Omega$  to  $(V_{CC} / 2)$ ,  $V_{SHDN} \geq 2V$ ,  $T_A = -40^\circ C$  to  $+85^\circ C$ , unless otherwise noted.)

PARAMETER	SYMBOL	CONDITIONS	MIN	TYP	MAX	UNITS
Off-Leakage Current in Shutdown	$I_{OUT(SHDN)}$	$V_{SHDN} < 0.8V$ , $V_{OUT} = 0V$ to $V_{CC}$			$\pm 5$	$\mu A$
Large-Signal Voltage Gain	$A_{VOL}$	$V_{CC} = 5V$	$V_{OUT} = 0.2V$ to $4.8V$ , $R_L = 100k\Omega$	90		dB
			$V_{OUT} = 0.6V$ to $4.4V$ , $R_L = 25\Omega$	66		
Output Voltage Swing	$V_{OUT}$	$V_{CC} = 5V$	$R_L = 100k\Omega$	$V_{CC} - V_{OH}$	40	mV
				$V_{OL} - V_{EE}$	30	
			$R_L = 25\Omega$	$V_{CC} - V_{OH}$	490	
				$V_{OL} - V_{EE}$	400	
Output Source/Sink Current (Note 2)		$V_{OUT} = 0.6V$ to $(V_{CC} - 0.6V)$	$\pm 80$			mA
SHDN Logic Threshold (Note 3)	$V_{IL}$	Shutdown mode			0.8	V
	$V_{IH}$	Normal mode	2.0			
SHDN Input Bias Current		$V_{EE} < V_{SHDN} < V_{CC}$			$\pm 3.5$	$\mu A$
Operating Supply-Voltage Range	$V_{CC}$	Inferred from PSRR test	2.7		6.5	V
Quiescent Supply Current (per Amplifier)	$I_{CC}$	$V_{CC} = 5V$			1.7	mA
		$V_{CC} = 3V$			1.6	
Shutdown Supply Current (per Amplifier)	$I_{CC(SHDN)}$	$V_{SHDN} < 0.8V$	$V_{CC} = 5V$		82	$\mu A$
			$V_{CC} = 3V$		54	

**Note 2:** Although the minimum output current is guaranteed to be  $\pm 80mA$ , exercise caution to ensure that the absolute maximum power-dissipation rating of the package is not exceeded.

**Note 3:** SHDN logic thresholds are referenced to  $V_{EE}$ .

**Note 4:** The MAX4165EUK is 100% tested at  $+25^\circ C$ . All temperature limits are guaranteed by design.

## AC ELECTRICAL CHARACTERISTICS

( $V_{CC} = +2.7V$  to  $+6.5V$ ,  $V_{EE} = 0V$ ,  $V_{CM} = 0V$ ,  $V_{OUT} = (V_{CC} / 2)$ ,  $R_L = 2.5k\Omega$  to  $(V_{CC} / 2)$ ,  $V_{SHDN} \geq 2V$ ,  $C_L = 15pF$ ,  $T_A = +25^\circ C$ , unless otherwise noted.)

PARAMETER	SYMBOL	CONDITIONS	MIN	TYP	MAX	UNITS
Gain-Bandwidth Product	GBWP			5		MHz
Full-Power Bandwidth	FPBW	$V_{OUT} = 4Vp-p$ , $V_{CC} = 5V$		260		kHz
Slew Rate	SR			2		V/ $\mu s$
Phase Margin	PM			68		degrees
Gain Margin	GM			21		dB
Total Harmonic Distortion	THD	$f = 10kHz$ , $V_{OUT} = 2Vp-p$ , $A_{VCL} = +1V/V$		0.005		%
Settling Time to 0.01%	$t_S$	$A_{VCL} = +1V/V$ , 2V step		2.1		$\mu s$
Input Capacitance	$C_{IN}$			3		pF
Input Voltage-Noise Density	$e_n$	$f = 1kHz$		26		$nV/\sqrt{Hz}$
Input Current-Noise Density	$i_n$	$f = 1kHz$		0.4		$pA/\sqrt{Hz}$
Channel-to-Channel Isolation		$f = 1kHz$ , $R_L = 100k\Omega$ (MAX4167-MAX4169)		125		dB
Capacitive Load Stability		$A_{VCL} = +1V/V$ , no sustained oscillations		250		pF
Shutdown Time	$t_{SHDN}$			1		$\mu s$
Enable Time from Shutdown	$t_{ENABLE}$			1		$\mu s$
Power-Up Time	$t_{ON}$			5		$\mu s$

# High-Output-Drive, Precision, Low-Power, Single-Supply, Rail-to-Rail I/O Op Amps with Shutdown

## Typical Operating Characteristics

( $V_{CC} = +5.0V$ ,  $V_{EE} = 0V$ ,  $R_L = 100k\Omega$ ,  $T_A = +25^\circ C$ , unless otherwise noted.)

MAX4165-MAX4169

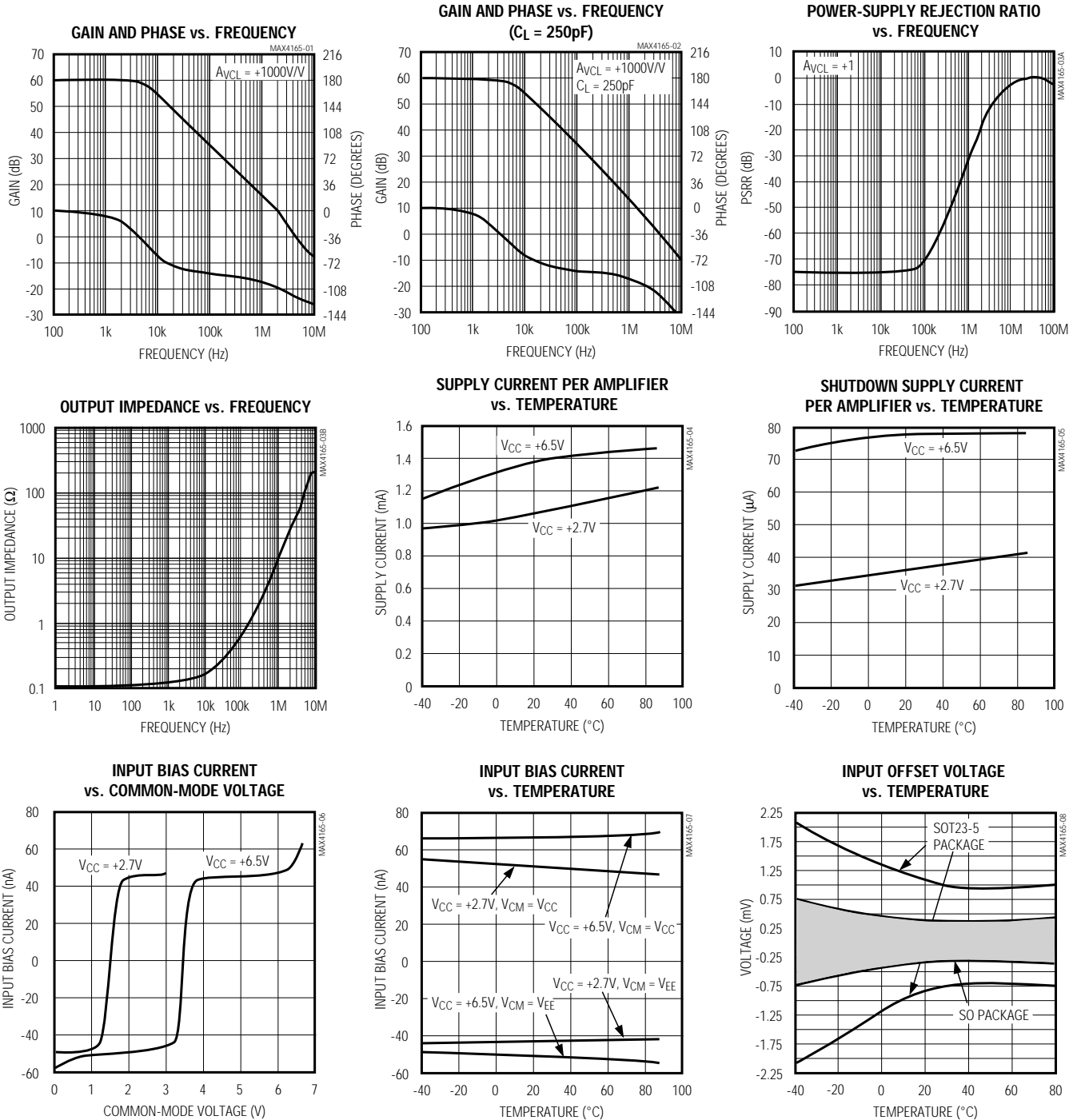

# High-Output-Drive, Precision, Low-Power, Single-Supply, Rail-to-Rail I/O Op Amps with Shutdown

## Typical Operating Characteristics (continued)

( $V_{CC} = +5.0V$ ,  $V_{EE} = 0V$ ,  $R_L = 100k\Omega$ ,  $T_A = +25^\circ C$ , unless otherwise noted.)

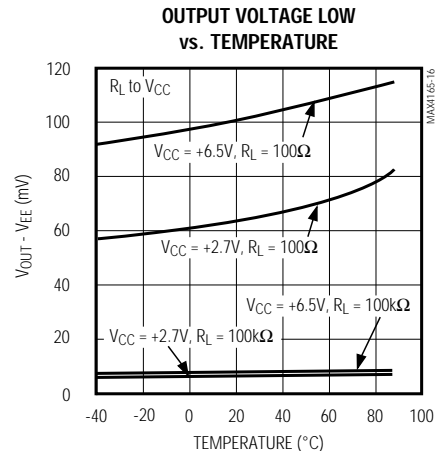
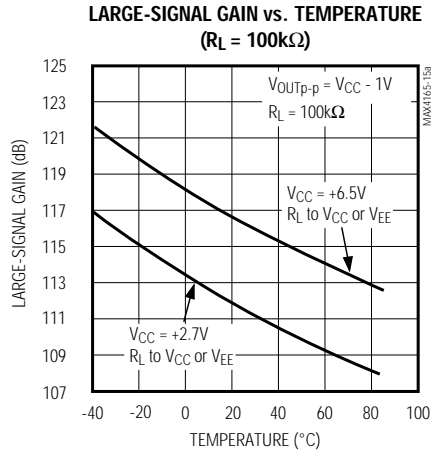
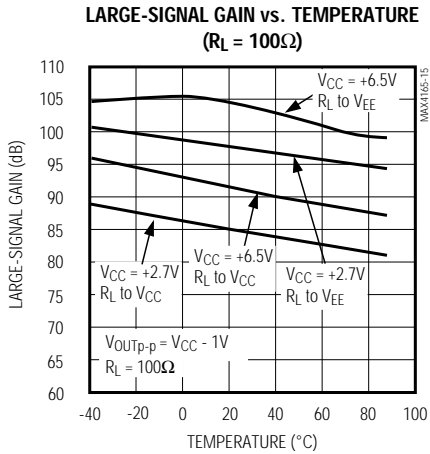
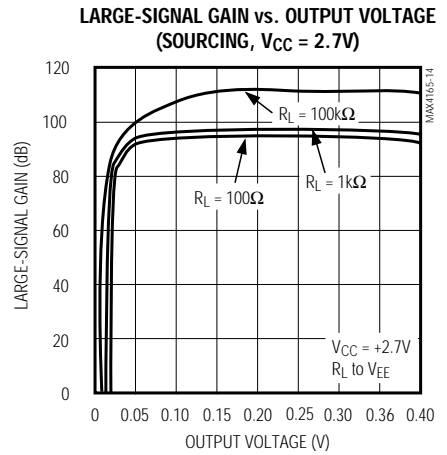
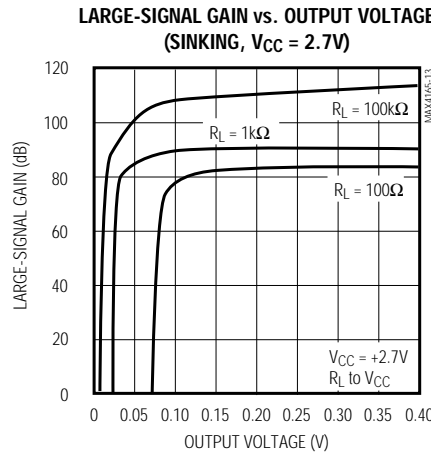
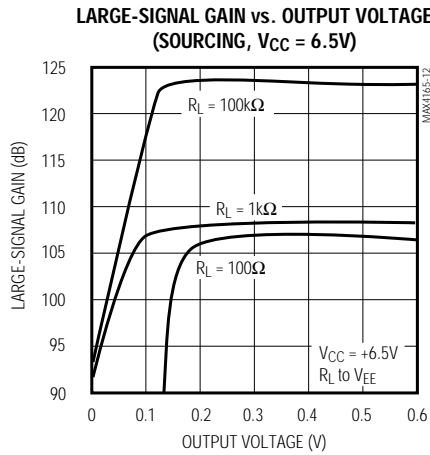
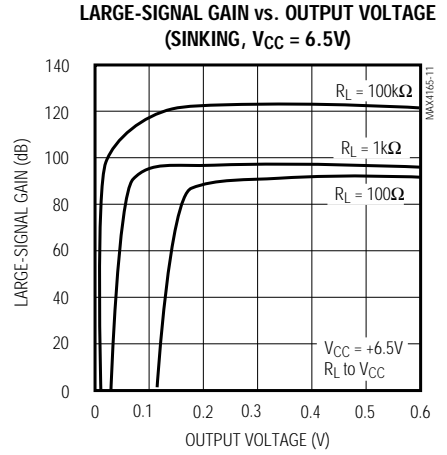
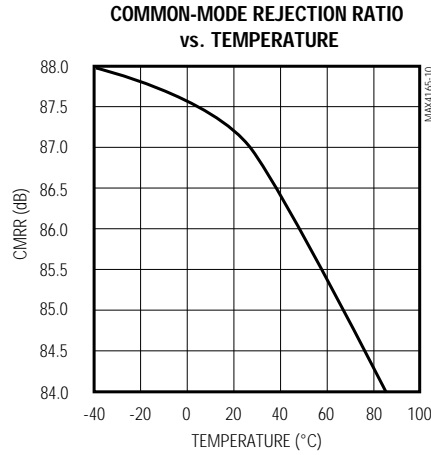
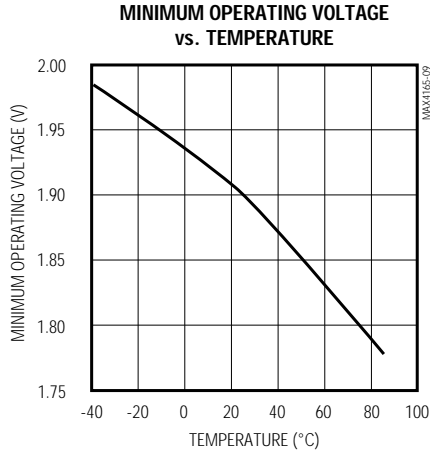

# High-Output-Drive, Precision, Low-Power, Single-Supply, Rail-to-Rail I/O Op Amps with Shutdown

## Typical Operating Characteristics (continued)

( $V_{CC} = +5.0V$ ,  $V_{EE} = 0V$ ,  $R_L = 100k\Omega$ ,  $T_A = +25^\circ C$ , unless otherwise noted.)

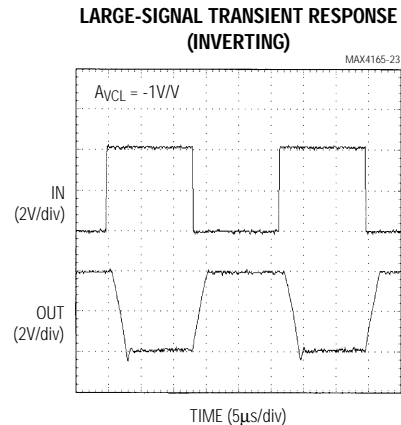
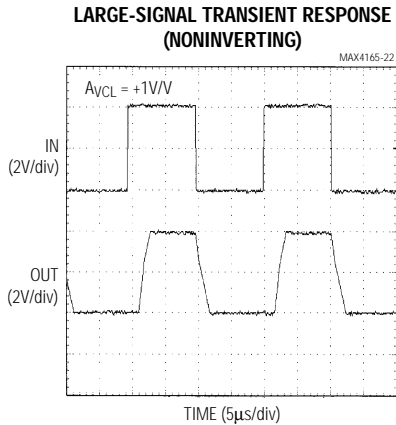
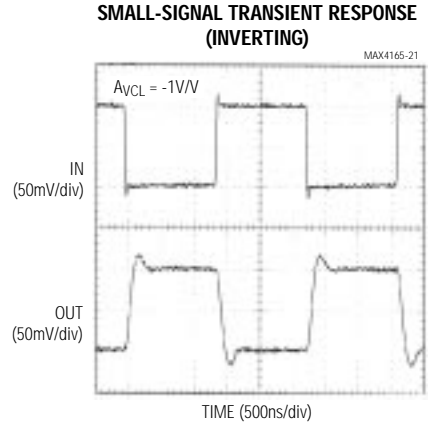
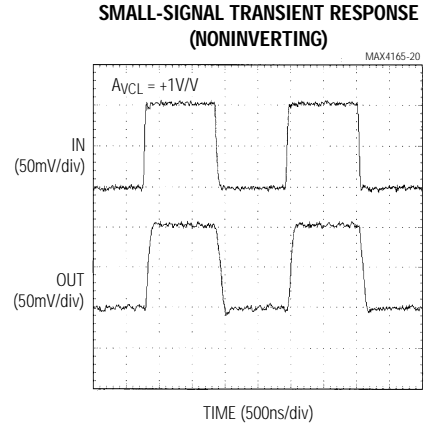
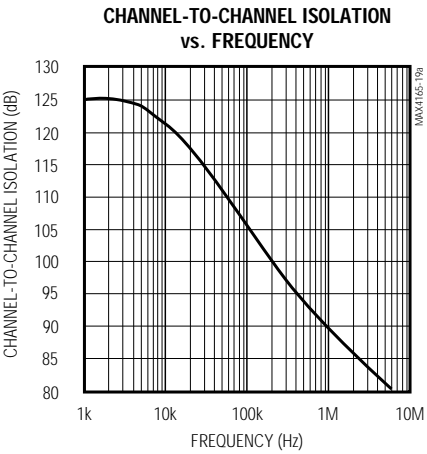
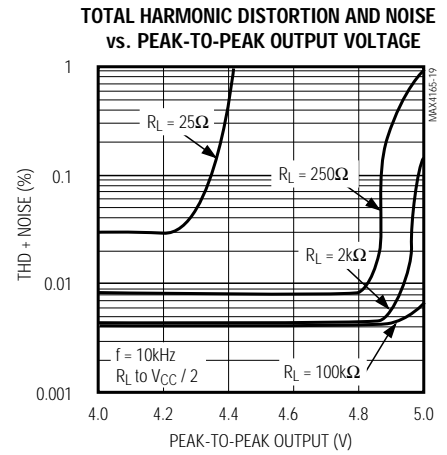
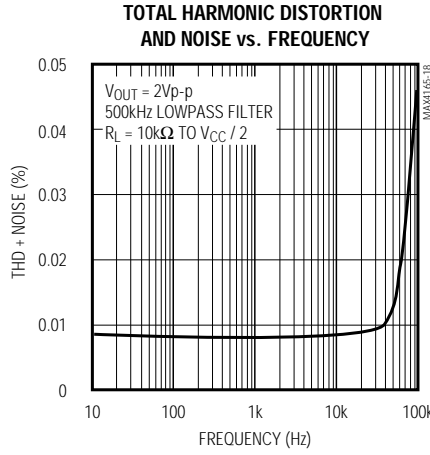
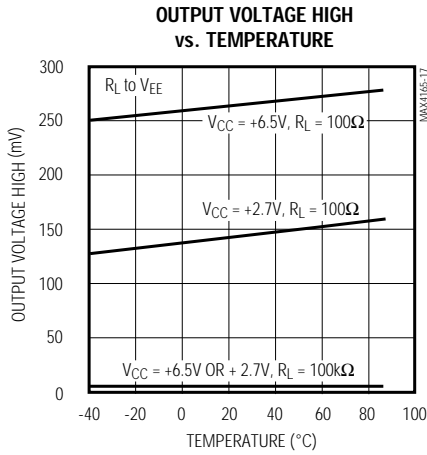

# High-Output-Drive, Precision, Low-Power, Single-Supply, Rail-to-Rail I/O Op Amps with Shutdown

## Pin Description

MAX4165-MAX4169

PIN						NAME	FUNCTION
MAX4165	MAX4166	MAX4167	MAX4168		MAX4169		
			DIP/SO	μMAX			
1	6	—	—	—	—	OUT	Output
—	1, 5	—	5, 7, 8, 10	—	—	N.C.	No Connection. Not internally connected.
—	—	1, 7	1, 13	1, 9	1, 7	OUT1, OUT2	Outputs for Amplifiers 1 and 2
2	4	4	4	4	11	V <sub>EE</sub>	Negative Supply. Ground for single-supply operation.
3	3	—	—	—	—	IN+	Noninverting Input
—	—	2, 6	2, 12	2, 8	2, 6	IN1-, IN2-	Inverting Inputs for Amplifiers 1 and 2
4	2	—	—	—	—	IN-	Inverting Input
—	—	3, 5	3, 11	3, 7	3, 5	IN1+, IN2+	Noninverting Inputs for Amplifiers 1 and 2
5	7	8	14	10	4	V <sub>CC</sub>	Positive Supply
—	—	—	6, 9	5, 6	—	$\overline{\text{SHDN1}}$ , $\overline{\text{SHDN2}}$	Active-Low Shutdown Inputs for Amplifiers 1 and 2. Drive low for shutdown mode. Drive high or connect to V <sub>CC</sub> for normal operation.
—	8	—	—	—	—	$\overline{\text{SHDN}}$	Active-Low Shutdown Input. Drive low for shutdown mode. Drive high or connect to V <sub>CC</sub> for normal operation.
—	—	—	—	—	8, 14	OUT3, OUT4	Outputs for Amplifiers 3 and 4
—	—	—	—	—	9, 13	IN3-, IN4-	Inverting Inputs for Amplifiers 3 and 4
—	—	—	—	—	10, 12	IN3+, IN4+	Noninverting Inputs for Amplifiers 3 and 4

# High-Output-Drive, Precision, Low-Power, Single-Supply, Rail-to-Rail I/O Op Amps with Shutdown

## Applications Information

### Package Power Dissipation

**Warning: Due to the high output current drive, this op amp can exceed the absolute maximum power-dissipation rating.** As a general rule, as long as the peak current is less than or equal to 80mA, the maximum package power dissipation will not be exceeded for any of the package types offered. There are some exceptions to this rule, however. The absolute maximum power-dissipation rating of each package should always be verified using the following equations. The following equation gives an approximation of the package power dissipation:

$$P_{IC(DISS)} \cong V_{RMS} I_{RMS} \cos \theta$$

where:  $V_{RMS}$  = the RMS voltage from  $V_{CC}$  to  $V_{OUT}$  when sourcing current

= the RMS voltage from  $V_{OUT}$  to  $V_{EE}$  when sinking current

$I_{RMS}$  = the RMS current flowing out of or into the op amp and the load

$\theta$  = the phase difference between the voltage and the current. For resistive loads,  $\cos \theta = 1$ .

For example, the circuit in Figure 1 has a package power dissipation of 157mW.

$$\begin{aligned} V_{RMS} &\cong (V_{CC} - V_{DC}) - \frac{V_{PEAK}}{\sqrt{2}} \\ &= 6.5V - 3.25V - \frac{1.5V}{\sqrt{2}} = 2.189V_{RMS} \end{aligned}$$

$$\begin{aligned} I_{RMS} &\cong I_{DC} + \frac{I_{PEAK}}{\sqrt{2}} = \frac{3.25V}{60\Omega} + \frac{1.5V/60\Omega}{\sqrt{2}} \\ &= 71.84mA_{RMS} \end{aligned}$$

Therefore,  $P_{IC(DISS)} = V_{RMS} I_{RMS} \cos \theta = 157mW$

Adding a coupling capacitor improves the package power dissipation because there is no DC current to the load, as shown in Figure 2.

$$\begin{aligned} V_{RMS} &\cong (V_{CC} - V_{DC}) - \frac{V_{PEAK}}{\sqrt{2}} \\ &= 6.5V - 3.25V - \frac{1.5V}{\sqrt{2}} = 2.189V_{RMS} \end{aligned}$$

$$\begin{aligned} I_{RMS} &\cong I_{DC} + \frac{I_{PEAK}}{\sqrt{2}} = 0A + \frac{1.5V/60\Omega}{\sqrt{2}} \\ &= 17.67mA_{RMS} \end{aligned}$$

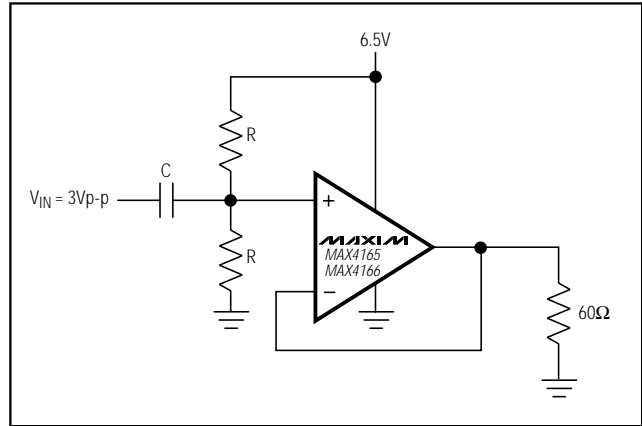

Figure 1. A Circuit Example where the MAX4165/MAX4166 is Being Used in Single-Supply Operation

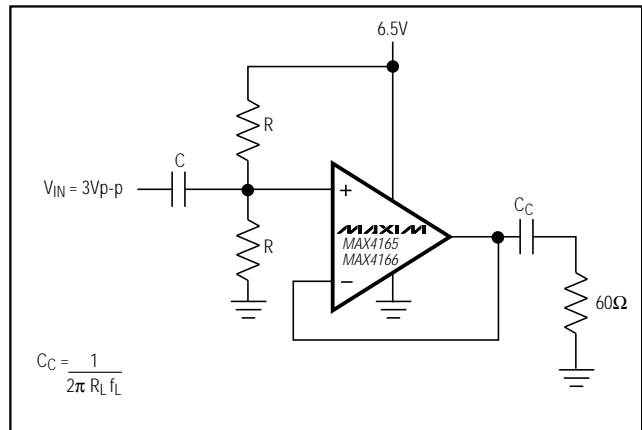

Figure 2. A Circuit Example where Adding a Coupling Capacitor Greatly Reduces the Power Dissipation of Its Package

Therefore,  $P_{IC(DISS)} = V_{RMS} I_{RMS} \cos \theta = 38.6mW$

The absolute maximum power-dissipation rating of this package would be exceeded if the configuration in Figure 1 were used with all four of the MAX4169ESD's amplifiers at a high ambient temperature of +75°C (157mW x 4 amplifiers = 628mW + a derating of 8.33mW/°C x 5°C = 669mW). Note that 669mW just exceeds the absolute maximum power dissipation of 667mW for the 14-pin SO package (see the *Absolute Maximum Ratings* section).















