

APPLICATION NOTE 967

How to Minimize Power Dissipation in Li+ Linear Chargers

Abstract: Techniques are described for minimizing power dissipation in linear battery chargers. Beginning with a stable wall-cube switching power source, methods are described to limit the dissipation in the linear charging circuit. Circuits are provided, calculations are shown, heat sinking for the PMOS pass transistor is discussed, and suitable pass transistors are suggested.

Introduction

Data sheets for single-cell Li+ linear chargers seldom discuss power dissipation or how to deal with heat dissipation. High input voltage and charge current increase the amount of power the pass element must handle. This application note discusses how to maximize charging current while maintaining safe device and system temperature limits.

Use a Proper DC Input Source

A low voltage input reduces the power dissipation. In order to charge the single-cell Li+ battery, we need a well regulated 4.2V±1% or 4.1V±1% (depending on battery chemistry) output. The input voltage needs to be higher to cover the voltage drops between the battery positive terminal and the input DC source. **Figure 1** shows these for a typical charger.

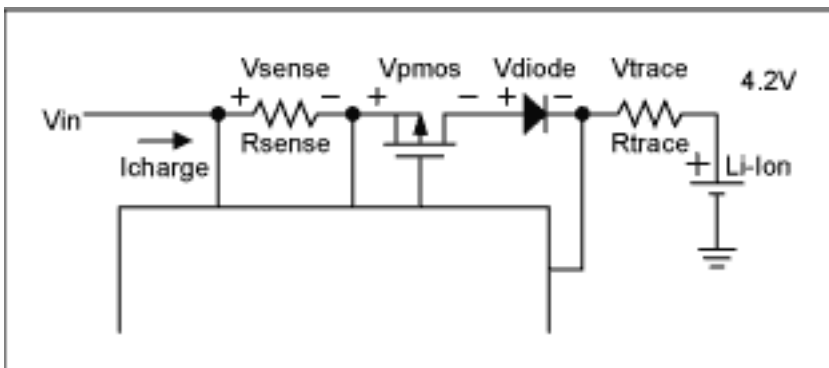

Figure 1. Voltage drop contribution.

$$V_{in} = V_{sense} + V_{pmos} + V_{trace} + V_{diode} + 4.2V$$

The minimum input can be described as below.

$$V_{in(min)} = R_{sense} \times I_{charge} + R_{ds(on)} \times I_{charge} + R_{trace} \times I_{charge} + (V_{thmax(d)} + R_d \times I_{charge}) + 4.2V$$

Where $V_{diode} = V_{thmax(d)} + R_d \times I_{charge}$, $V_{thmax(d)}$; Diode turn on threshold voltage, R_d ; Diode series resistance

As we see in the above equation, the charger requires higher input voltage if the charge current (I_{charge}) is increased. Below is actual data from an example circuit (Figure 4) when the charge current is 500mA.

$$V_{in} = 0.303V(V_{diode}) + 0.060V(V_{sense}) + 0.112V(V_{pmos}) + 0.000V(V_{trace}) + 4.2V$$

$$V_{in} = 4.68V$$

Schottky diode: Zetex ZHCS1000,

PMOS FET: Fairchild FDC636P,

$$R_{sense} = 105m\Omega,$$

R_{trace} : 40mils wide, 0.5" long, and 1 oz copper trace. This value depends upon PCB layout and battery contacts.

Since this data was taken from one prototype, we should also consider the tolerances of each parameter. A 5V $\pm 5\%$ well-regulated switching mode AC adapter will provide some margin, to account for tolerances. The AC adapter does not need an accurate current limit since the charger has a current control, but the AC adapter maximum current capability must be 200-300mA higher than the fast charge current of the linear charger.

Figure 2 shows an example of an AC adapter using a MAX5021 low-power, current-mode PWM controller.

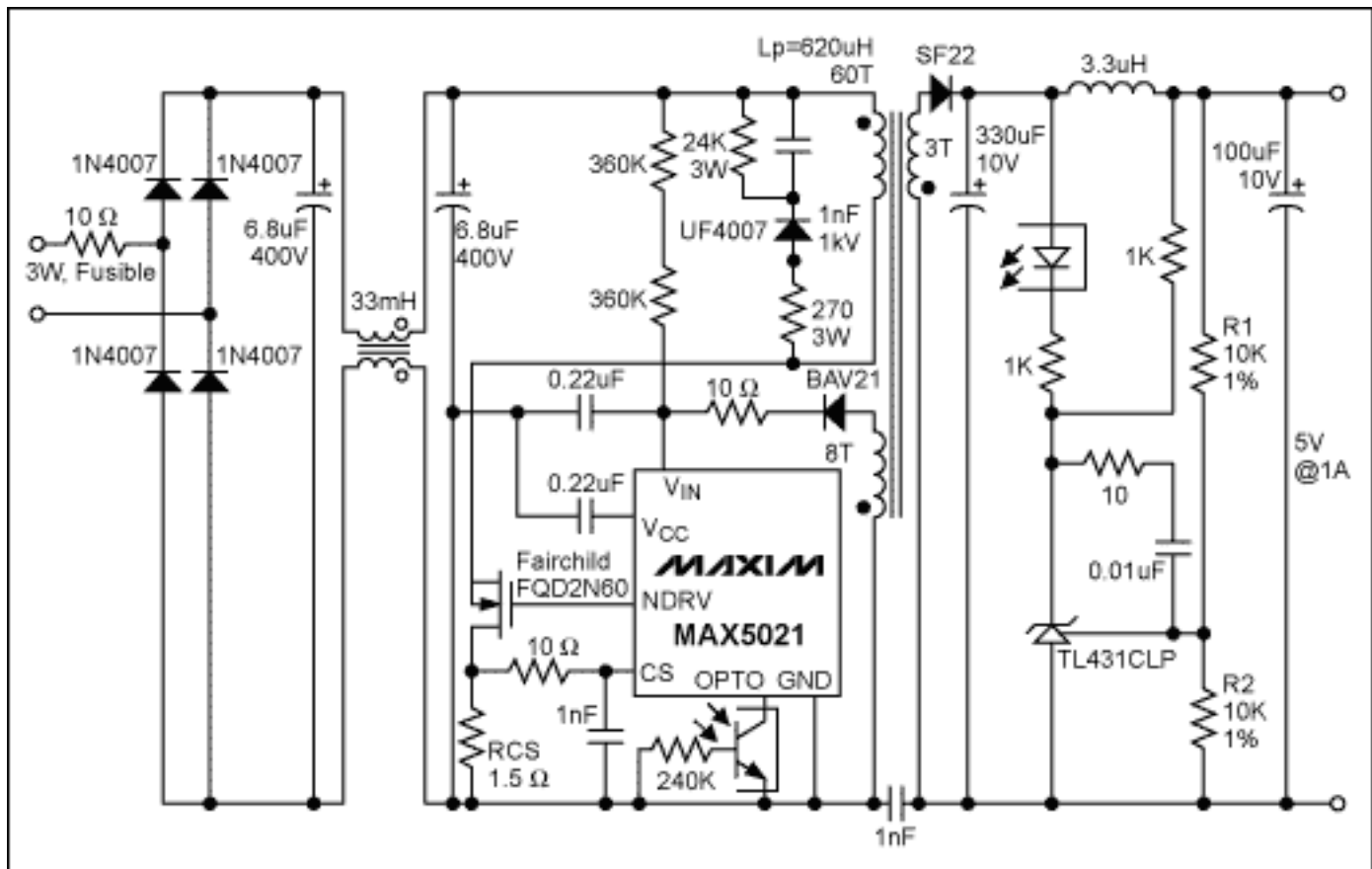

Figure 2. 5V/1A AC adapter.

Optimize Charge Current and Power Dissipation

Figure 3 shows the circuit used for testing. It is a linear charger with a 500mA charge current and a 6 hours timer limit.

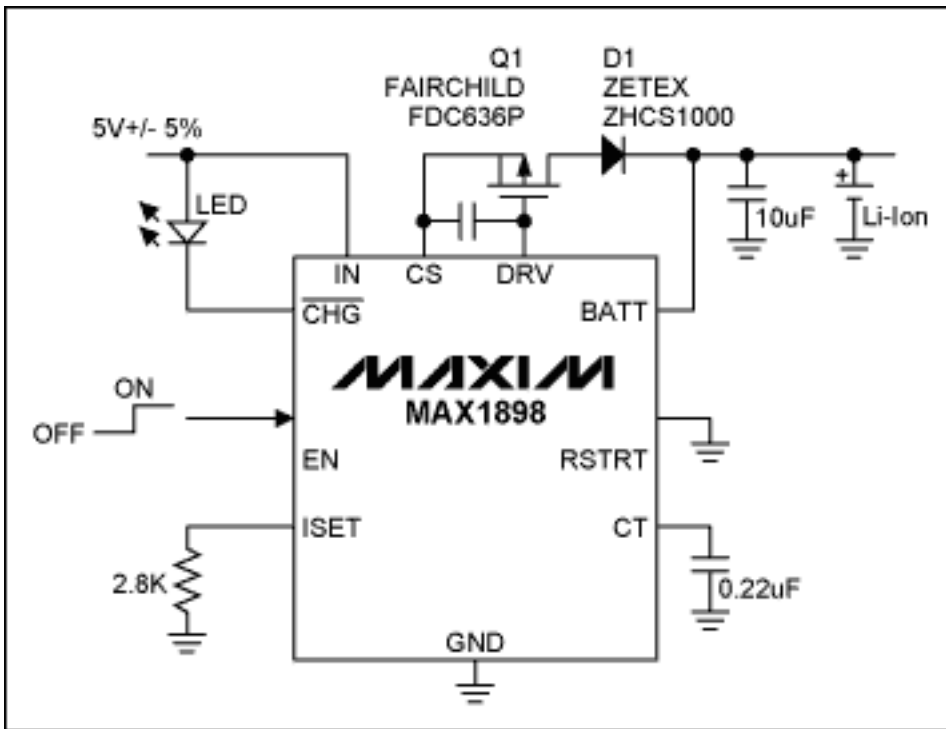

Figure 3. The MAX1898 single-cell Li+ linear charger.

Total power dissipation for the linear charger can be expressed as below.

$$P_{diss} = (V_{in} - V_{batt}) \times I_{charge}$$

To decide the fast charging current, we need to calculate the worst-case allowable power dissipation on the P-MOSFET Q1.

Power dissipation on the Q1 is expressed as below:

$$P_{diss}(Q1) = V_{ds}(Q1) \times I_{charge}$$

$$V_{ds}(Q1) = 5V - V_{D1} - I_{charge} \times R_{cs} - V_{batt}$$

Where V_{D1} : D1 forward voltage drop, R_{cs} : internal current sensing resistor.

Also, the junction temperature of the P-MOSFET should not exceed its maximum limit = 150°C at any operating conditions.

$$T_j = T_a + R_{\theta JA} \times P_{diss}(Q1)$$

Table 1 shows some possible P-MOSFET products that can be used in the charger. Even though the specifications show quite high maximum power dissipations, we should be cautious of the PCB mount condition. The "1 in_ pad of 2oz Cu on FR-4 board" specified for package rating on many MOSFET devices may not be realistic for many applications. Instead, the following design procedure yields more practical results.

Table 1.

	Package	Pd, Maximum Power Dissipation	R θ JA, R θ JC, R θ CA Thermal Resistance	PCB Mount
FAIRCHILD FDC636P	SuperSot-6	1.6W at 25°C	R θ JA= 78°C/W R θ JC= 30°C/W R θ CA= 48°C/W	1 in_ pad of 2oz Cu on FR-4 board.
		0.8W at 25°C 0.417W at 85°C	R θ JA =156°C/W R θ JC= 30°C/W R θ CA= 126°C/W	Minimum pad of 2oz Cu on FR-4 board.
Vishay Siliconix Si3441DV	TSOT-6	1.1W at 25°C	R θ JA =110°C/W R θ JC= 30°C/W R θ CA= 80°C/W	Surface Mounted on 1 in_ FR4 board
		0.6W at 85°C		
Vishay Siliconix Si5443DC	1206-8 ChipFET	1.3W at 25°C	R θ JA =95°C/W R θ JC= 20°C/W R θ CA= 75°C/W	Mounted on 1 in_ FR4 board

At first, we should figure out the best R θ JA that we could get given the system design restrictions. The R θ JA is the sum of the junction-to-case (R θ JC) and case-to-ambient thermal resistance (R θ CA), where the case thermal reference is defined as the solder mounting surface of the drain pins. R θ JC is guaranteed by design, while R θ CA is determined by the user's board design, heatsinking method, and a cooling system. We should reduce the R θ CA as low as possible. However, there will be some restrictions such as a limited board space, no ventilation, and safety requirements for PCB material. Since we cannot measure the Tj directly, we can use Tc to compute R θ CA.

$$T_c = T_a + R_{\theta CA} \times P_{diss}(Q1)$$

$$R_{\theta CA} = (T_c - T_a) / P_{diss}(Q1)$$

To design an efficient heatsink for a surface mount PMOS FET, we should increase the drain pin board areas as much as we can. And then we can measure the Vd-s (Q1), Icharge, and Tc to calculate R θ CA. If the measured R θ CA is lower than what we expect, we should increase the surface area of the drain pin pads or reduce the charge current. Also, we should keep in mind that Tc must not exceed 130°C or 150°C PCB maximum operating temperature, depending upon PCB materials. We should check UL file numbers of PCB material that we use and their maximum operating temperature before we start. Let's assume we are using FR-4 two layer boards rated at 130°C max.

If the measured case temperature Tc is 125°C at Ta = 50°C and Pdiss(Q1) = 800mW,

$$125^\circ\text{C} = 50^\circ\text{C} + R_{\theta CA} \times 800\text{mW}$$

$$R_{\theta CA} = (125^\circ\text{C} - 50^\circ\text{C}) / 0.8\text{W}$$

$$= 93.75^\circ\text{C/W}$$

If R θ CA = 93.75°C/W, R θ CJ = 30°C/W (TSOP-6), Ta(max)= 50°C, and Tj(max) = 150°C, the maximum power dissipation that we can achieve;

$$150^\circ\text{C} = 50^\circ\text{C} + 123.75^\circ\text{C/W} \times P_{diss}(Q1)$$

$$P_{diss}(Q1)_{\text{max}} = 808\text{mW}$$

If the initial Vbatt = 3.0V, Rcs = 105m Ω , and VD1 = 0.35V at Icharge = 500mA, the worst case Vds(Q1) max is;

$$V_{ds}(Q1)_{\text{max}} = 5\text{V} - V_{D1} - I_{\text{charge}} \times R_{cs} - V_{\text{batt}} = 1.40\text{V}$$

The allowable maximum charge current is:

$$I_{\text{charge}}(\text{max}) = P_{\text{diss}}(Q1)_{\text{max}} / V_{ds}(Q1)_{\text{max}}$$

= 808mW/1.60V

= 505mA

Of course, the power dissipation will gradually drop as the battery voltage rises.

Conclusion

We can deliver a safe and reliable linear charger for a single-cell Li+ battery by optimizing the DC input source, the charge current, and the power dissipation with proper heatsinking method. Figure 4 shows an actual test result using the MAX1898 charger with a 4.2V, 900mA Li+ cell and a regulated 5V/1A MAX5021 AC adapter.

Application Note 967: <http://www.maxim-ic.com/an967>

More Information

For technical questions and support: <http://www.maxim-ic.com/support>

For samples: <http://www.maxim-ic.com/samples>

Other questions and comments: <http://www.maxim-ic.com/contact>

Related Parts

MAX1898: [QuickView](#) -- [Full \(PDF\) Data Sheet](#) -- [Free Samples](#)

MAX5021: [QuickView](#) -- [Full \(PDF\) Data Sheet](#) -- [Free Samples](#)

AN967, AN 967, APP967, Appnote967, Appnote 967

Copyright © by Maxim Integrated Products

Additional legal notices: <http://www.maxim-ic.com/legal>