



APPLICATION NOTE 914

WCDMA Upconverter/Driver Eliminates SAW Filter (Supports 570MHz IF)

Abstract: The MAX2383 was originally characterized with an intermediate frequency (IF) of 380MHz. This application note demonstrates the components required and the performance achievable with an IF of 570MHz. A complete application circuit and performance curves for output power, ACPR, gain, etc., over temperature and frequency are provided.

Additional Information:

- [Wireless Product Line Page](#)
- [MAX2383](#)
- [MAX2391](#)
- [MAX2394/MAX2395](#)
- Application Note 2233: [Block Diagram and Description of Maxim's TDD-WCDMA Transceiver Solution at 1.9GHz](#)
- [Applications Technical Support](#)

The MAX2383 upconverter and PA driver is designed for WCDMA (wideband-code division multiple access) applications in Japan (ARIB) and Europe (ETSI-UMTS) over the IMT-2000 frequency band. The device includes an upconversion mixer with variable gain control and local oscillator (LO) buffer, as well as a variable-gain PA driver. The upconverter features greater than 30dB of gain control range to support automatic gain control (AGC) loops. In addition, the MAX2383 automatically decreases PA driver and mixer supply current as the output power is reduced.

The MAX2383 was originally characterized with an intermediate frequency (IF) of 380MHz. This application note demonstrates the components required and the performance achievable with an IF of 570MHz. **Figures 1** through **6** demonstrate the performance of the MAX2383 over temperature, frequency and supply variations. All tests targeted achieving the maximum output power, while meeting adjacent channel power ratio (ACPR) requirements of -46dBc.

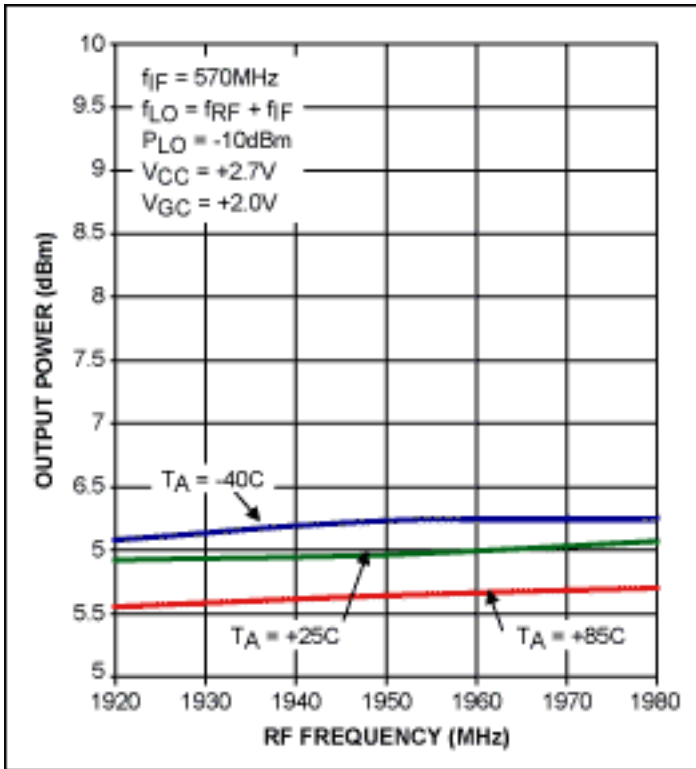

Figure 1. MAX2383 output power vs. RF frequency (ACPR = -46dBc, $V_{CC} = +2.7V$).

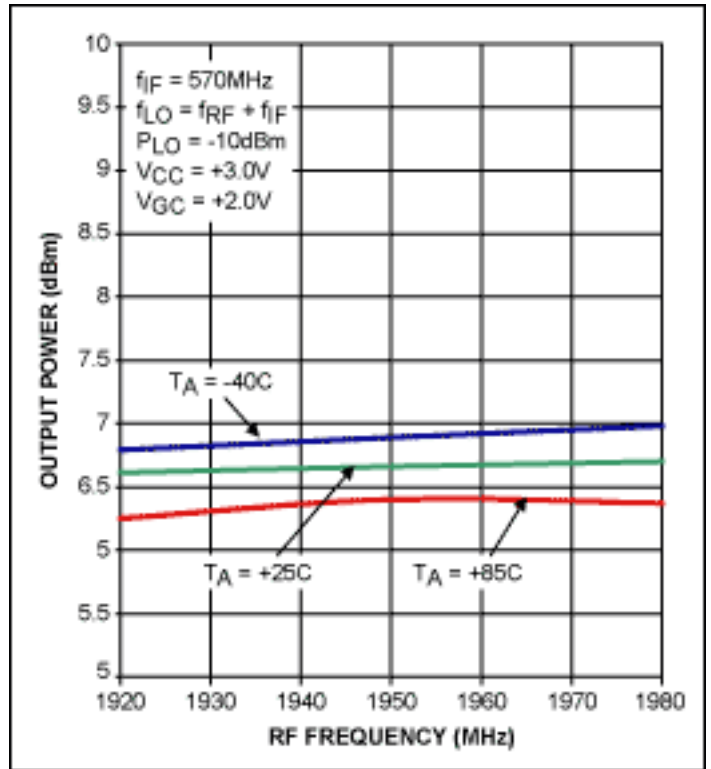

Figure 2. MAX2383 output power vs. frequency (ACPR = -46dBc, $V_{CC} = +3.0V$).

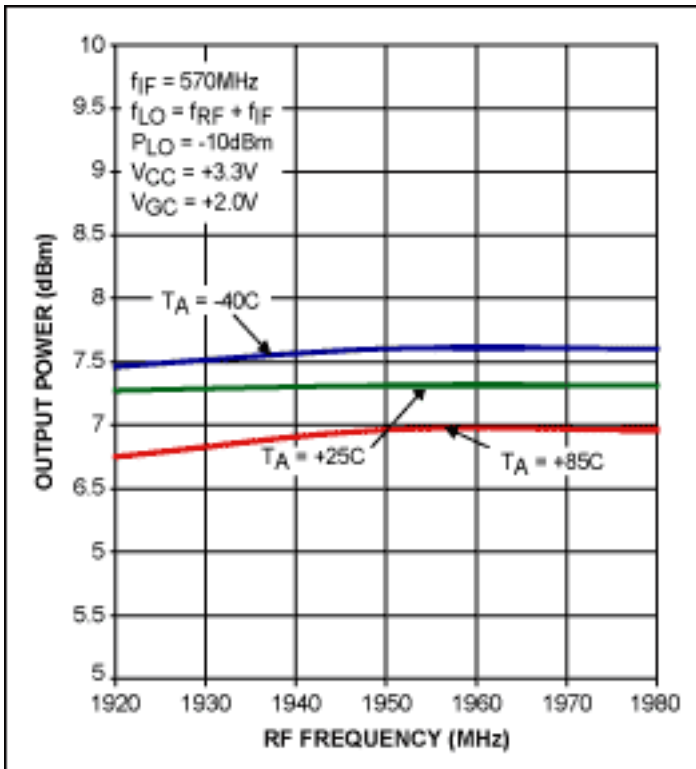

Figure 3. MAX2383 output power vs. frequency (ACPR = -46dBc, $V_{CC} = +3.3V$).

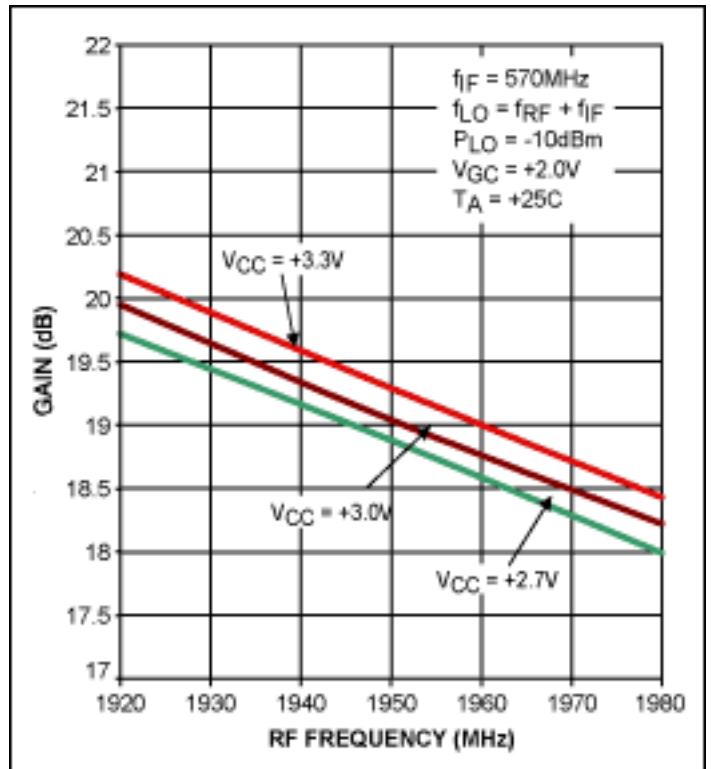

Figure 4. MAX2383 gain vs. frequency over supply variations (ACPR = -46dBc).

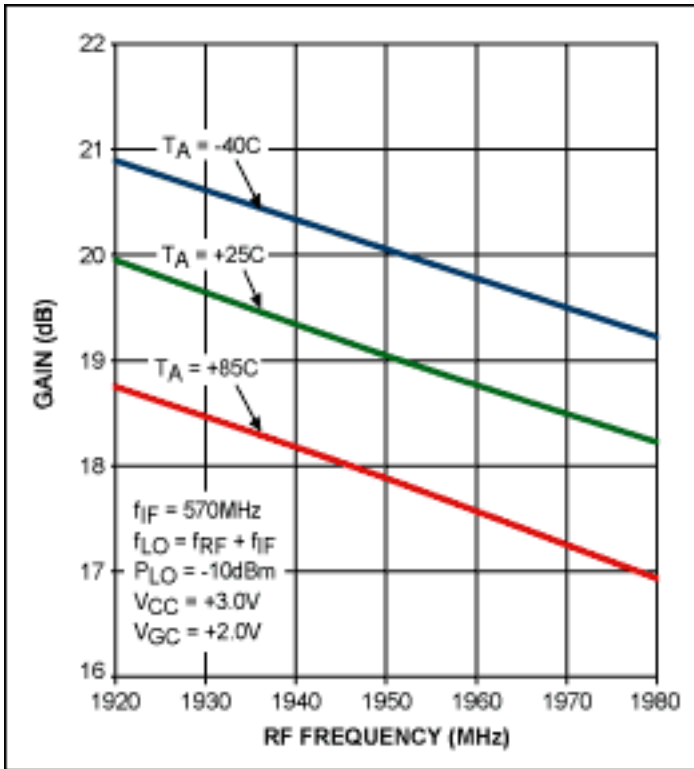

Figure 5. MAX2383 gain over temperature variations (ACPR = -46dBc).

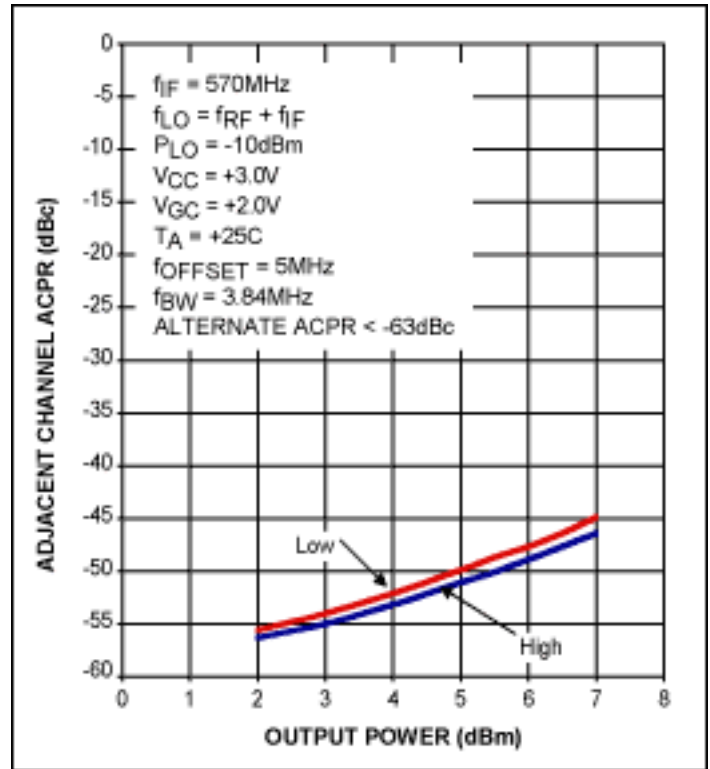

Figure 6. MAX2383 adjacent channel ACPR vs. output power.

Nominally, the MAX2383 delivered +6dBm of output power, with 19dB of gain from a 2.7V over frequency, at room temperature ($T_A = +25^\circ\text{C}$). Under worst case conditions ($V_{CC} = 2.7\text{V}$, $T_A = +85^\circ\text{C}$, over the 1920MHz to 1980MHz frequency band), the device delivered over +5.6dBm of output power while meeting -46dBc ACPR requirements in the neighboring channel. ACPR performance in the alternate channel was always greater than -64dBc. **Figure 7** lists the components required on the MAX2383 evaluation kit, for an IF of 570MHz, a high-side LO of 2520MHz, and an RF of 1950MHz.

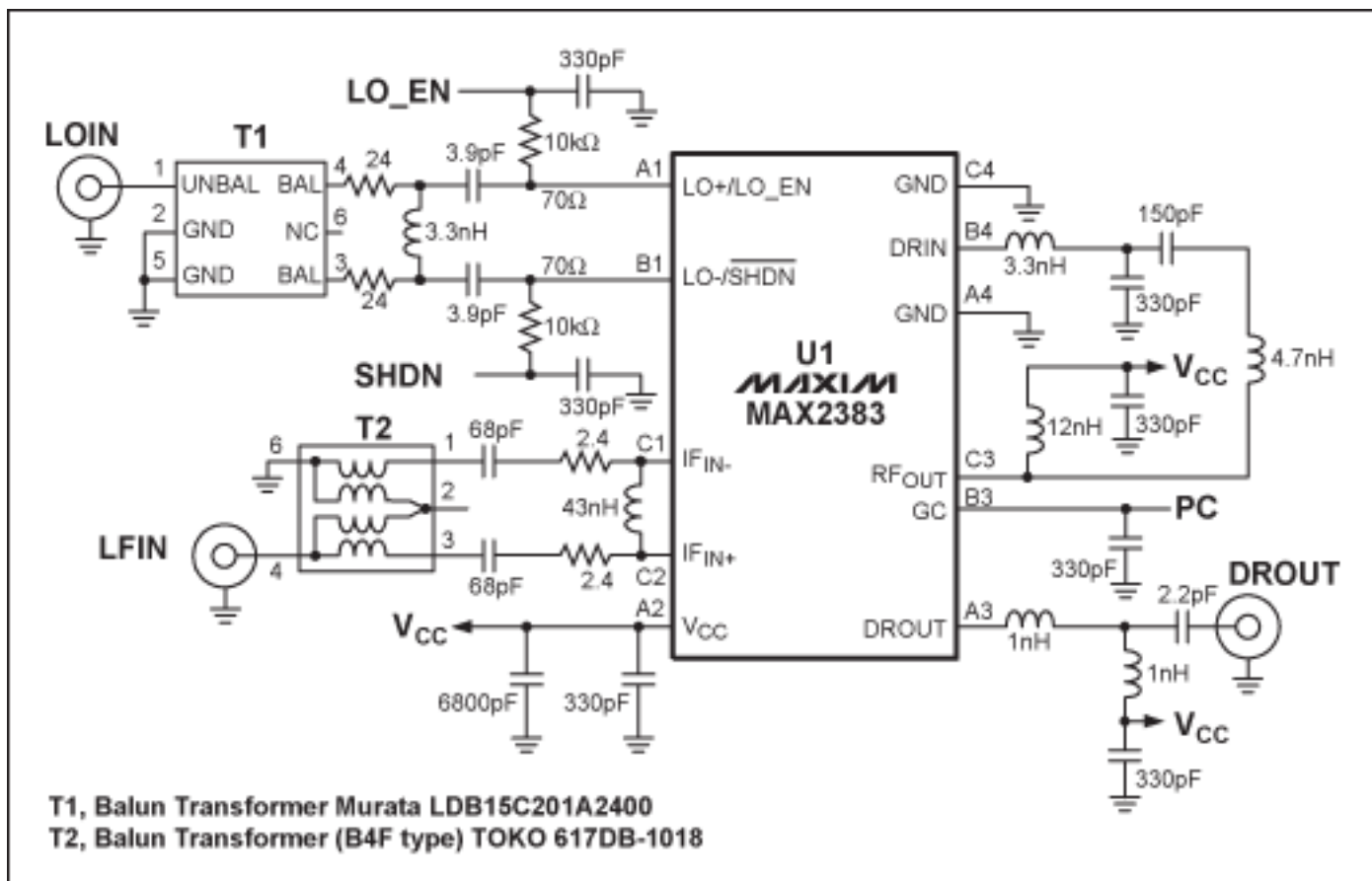

Figure 7. MAX2383EVKIT tuned for 570MHz IF.

For further device and performance information, refer to the [MAX2383 data sheet](#) and [MAX2383EVKIT data sheet](#).

Application Note 914: www.maxim-ic.com/an914

More Information

For technical questions and support: www.maxim-ic.com/support

For samples: www.maxim-ic.com/samples

Other questions and comments: www.maxim-ic.com/contact

Keep Me Informed

Preview new application notes in your areas of interest as soon as they are published. Subscribe to [EE-Mail - Application Notes](#) for weekly updates.

Related Parts

MAX2383: [QuickView](#) -- [Full \(PDF\) Data Sheet](#)

AN914, AN 914, APP914, Appnote914, Appnote 914

Copyright © by Maxim Integrated Products

Additional legal notices: www.maxim-ic.com/legal