



APPLICATION NOTE 890

## Silicon Germanium (SiGe) Downconverter Tuned for GPS Receivers

*Abstract: The RF input for a global positioning system (GPS) receiver is 1575MHz. Assuming an IF of 85MHz, and low-side LO injection ( $f_{LO} = 1490\text{MHz}$ ), the MAX2682 achieves +12.0dB of gain, has a noise figure of 9.2dB, an input third-order intercept point (IIP3) of +1.8dBm and draws 14.7mA of supply current from a +3.0V supply.*

### Additional Information

- [Wireless Product Line Page](#)
- [Quick View Data Sheet for the MAX2682/MAX2681/MAX2682 Downconverters](#)
- [Applications Technical Support](#)

The MAX2682 is one of a family of Silicon Germanium (SiGe) downconverters designed for low-voltage, low-current operation, and is ideal for portable communications equipment. The MAX2682 can be used with input radio frequencies (RFs) between 400MHz and 2500MHz, to downconvert to intermediate frequencies (IFs) between 10MHz to 500MHz. The RF input for a global positioning system (GPS) receiver is 1575MHz. Assuming an IF of 85MHz, and low-side LO injection ( $f_{LO} = 1490\text{MHz}$ ), the MAX2682 achieves +12.0dB of gain, has a noise figure of 9.2dB, an input third-order intercept point (IIP3) of +1.8dBm and draws 14.7mA of supply current from a +3.0V supply. See **Figure 1** for component values and the schematic. For application of the MAX2682 at 900MHz, 1950MHz or 2450MHz, or for further device information, consult the [MAX2680/MAX2681/MAX2682 Silicon Germanium \(SiGe\) Downconverters data sheet](#).

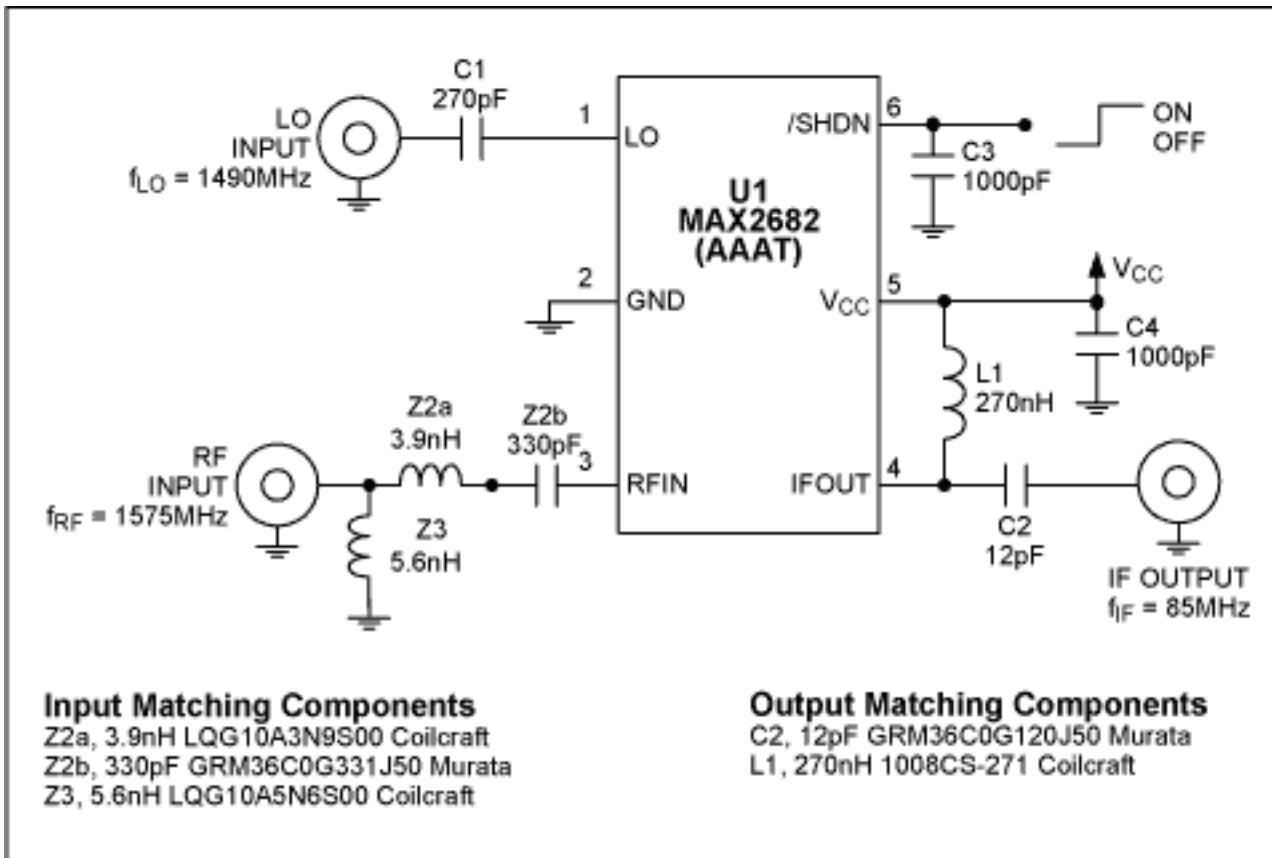

Figure 1. MAX2682 Silicon Germanium (SiGe) downconverter mixer for GPS applications.

**Table 1. MAX2682 SiGe Downconverter GPS Performance**

$V_{CC} = +3.0V$ ,  $f_{RF1} = 1575MHz$ ,  $f_{RF2} = 1576MHz$ ,  $f_{LO} = 1490MHz$ ,  $P_{LO} = -5dBm$ ,  $f_{IF} = 85MHz$

Parameter	Measured Performance
Conversion Gain	+12.0dB
Noise Figure	9.2dB
Input Third-Order Intercept Point	+1.8dBm
RF Input Return Loss	-35dB
IF Output Return Loss	-23dB
Supply Current	14.7mA

Application Note 890: <http://www.maxim-ic.com/an890>

### More Information

For technical questions and support: <http://www.maxim-ic.com/support>

For samples: <http://www.maxim-ic.com/samples>

Other questions and comments: <http://www.maxim-ic.com/contact>

### Related Parts

MAX2682: [QuickView](#) -- [Full \(PDF\) Data Sheet](#)

AN890, AN 890, APP890, Appnote890, Appnote 890

Copyright © by Maxim Integrated Products

Additional legal notices: <http://www.maxim-ic.com/legal>