

## APPLICATION NOTE 780

# CATV Upstream Amplifier Selection Guide

*Abstract: A selection guide to distinguish the MAX3503, MAX3505, MAX3507, MAX3509, MAX3510, MAX3514, and MAX3516 upstream driver amplifiers for cable modem and CATV systems. Parts meet DOCSIS and EuroDOCSIS standards.*

## Introduction

This note compares the features and functions of Maxim's family of CATV upstream amplifiers. It describes six parts, with key functional differences and performance graphs.

## MAX3510

When the MAX3510 was introduced, it quickly became the industry-standard CATV Upstream amplifier. It features a differential input/output with current-drive outputs. The MAX3510 significantly exceeds the burst on/off transient level for DOCSIS (see **Figure 1**). At 60dBmV output the MAX3510 guarantees a maximum transient level of 37mVp-p and achieves a typical performance of 7mVp-p, far below the 100mVp-p limit set by DOCSIS. The MAX3510 also surpasses the DOCSIS in-band transmit-disable mode noise requirement of -59dBmV. The MAX3510 maximum transmit-disable mode noise is -70dBmV maximum over -40°C to +85°C.

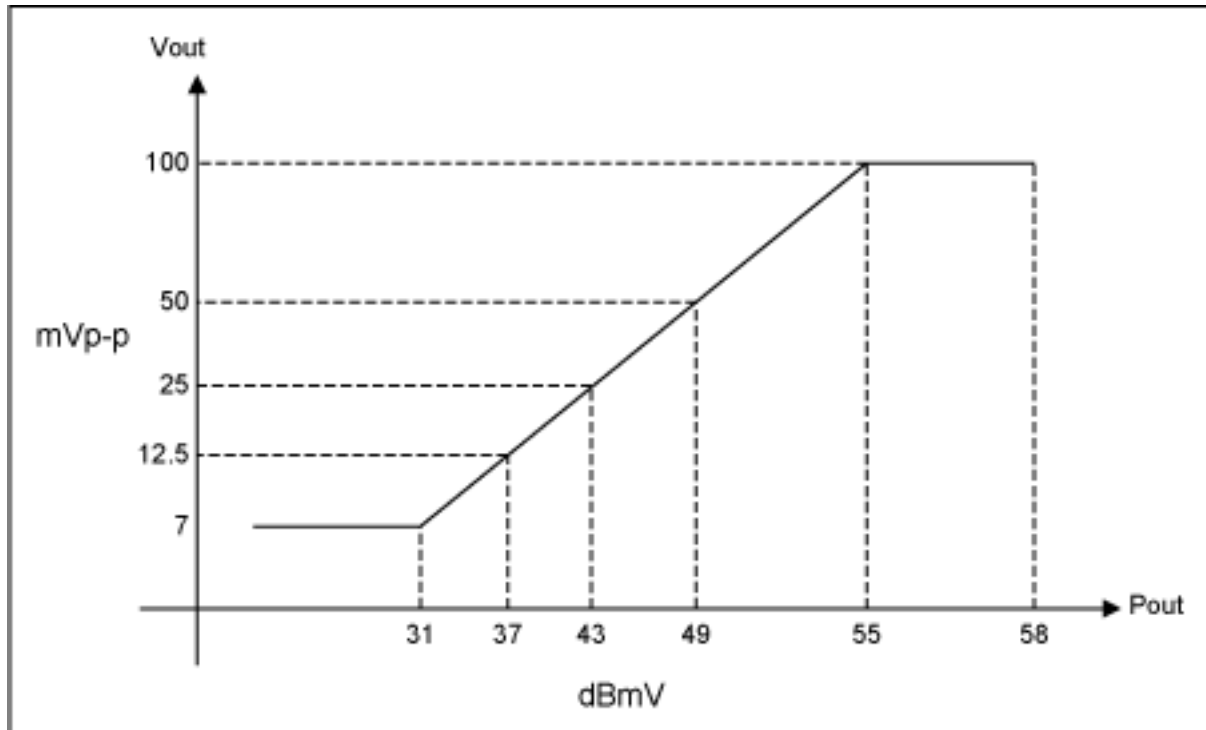

Figure 1. Burst ON/OFF transient level for DOCSIS.

## MAX3514

To address the extended frequency range (65MHz) of Euro-DOCSIS, the MAX3514 was introduced. Like the MAX3510, it features a differential input/output, with current-drive outputs. It has a much tighter gain specification over temperature and gain code word (See **Figure 2**). The gain variation is typically  $\pm 1\text{dB}$  (fixed gain code  $0^\circ\text{C}$  to  $85^\circ\text{C}$ ) allowing for 1dB in-band ripple from the diplex filter. This will dramatically ease the calibration of the cable modems firmware for power level. The MAX3514 performs extremely well for DOCSIS cable modem and dual design EuroDOCSIS/DOCSIS cable modems. The MAX3514 is replacing the MAX3510 as the new industry standard. The MAX3514 is pin-for-pin compatible with the MAX3510.

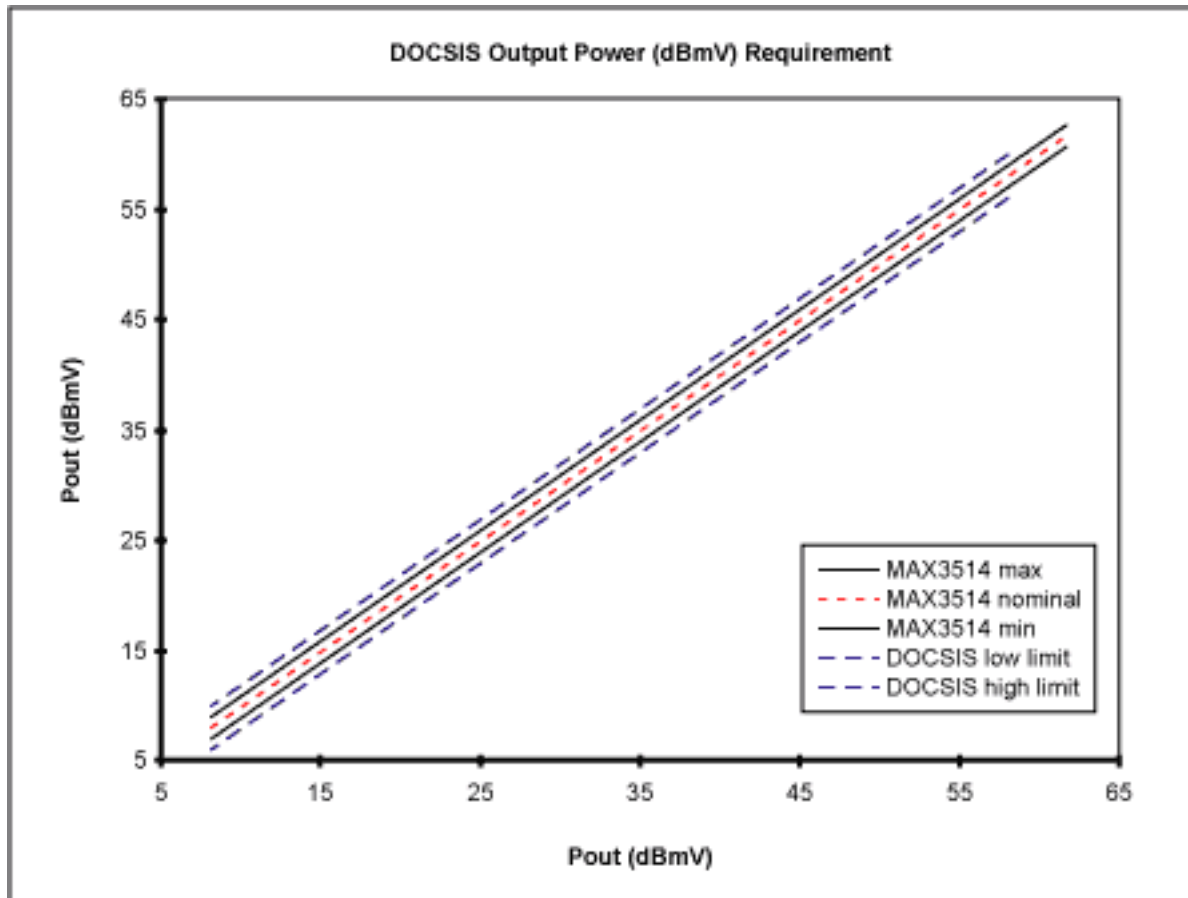

Figure 2. Upstream power level for DOCSIS and MAX3514 performance.

The MAX3514 exceeds the DOCSIS in-band transmit-disable mode noise requirement of  $-59\text{dBmV}$ . The part's maximum transmit-disable mode noise is  $-71\text{dBmV}$  maximum over  $-40^\circ\text{C}$  to  $+85^\circ\text{C}$ . DOCSIS requires a 50dB output power range (see **Figure 3**) and a 1dB gain step.

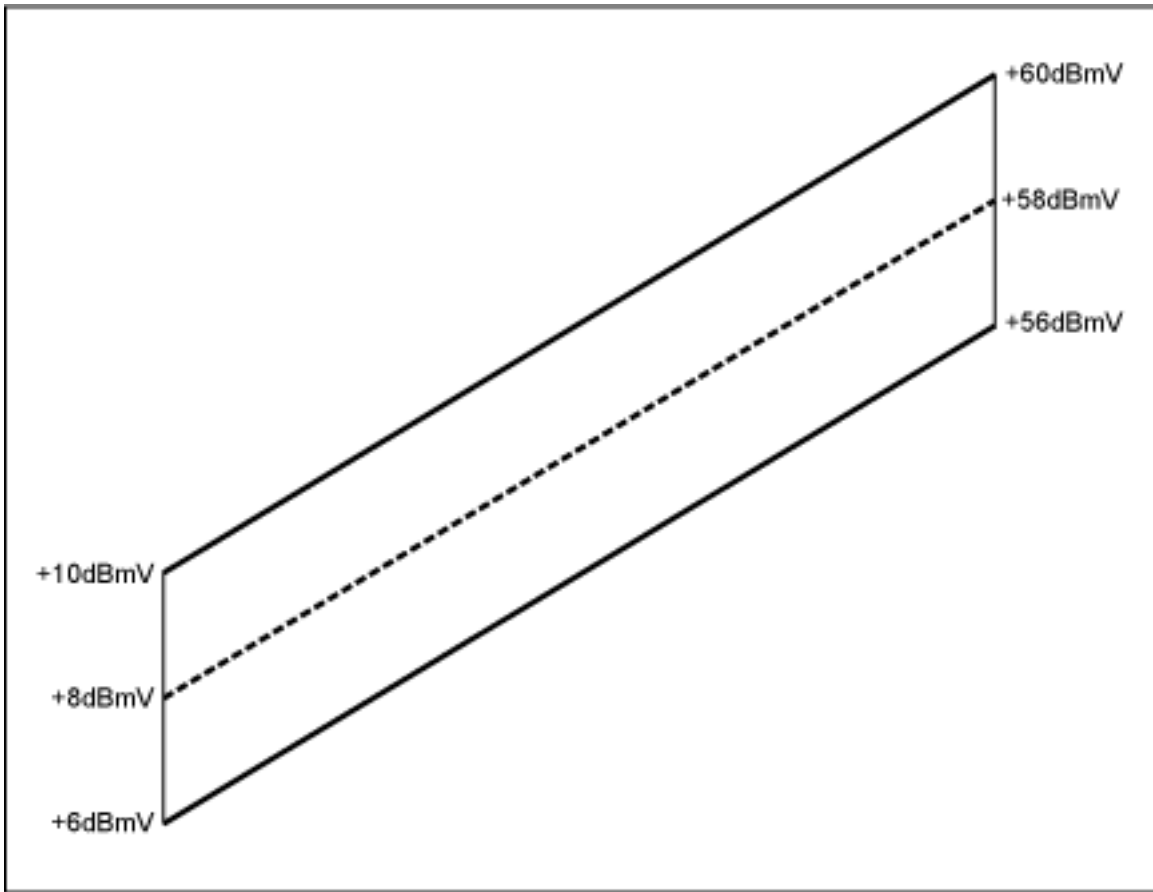

Figure 3. Upstream power level for DOCSIS.

Real world applications may require more range to overcome amplifier gain roll off and diplexer roll off at the band edge of 42MHz (see **Figure 4**). This of course depends on the individual diplexer design characteristics.

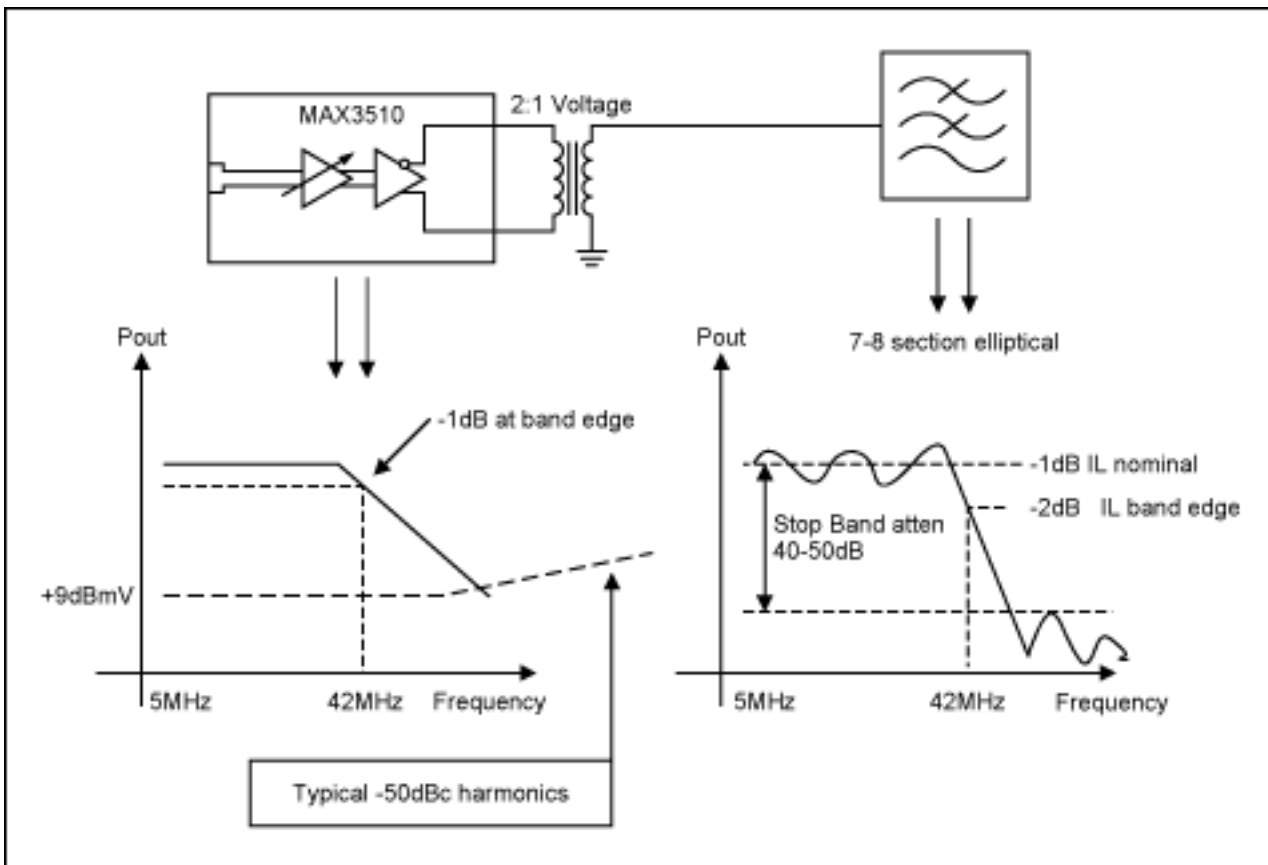

Figure 4. Band edge losses.

The MAX3514 has 56dB gain control range and 0.5dB gain steps. The MAX3514 has superior harmonic performance. The data sheet specification is -55dBc second harmonic 33MHz at 61dBmV and -55dBc third harmonic 22MHz at 61dBmV. Harmonic performance improves as the frequency is lowered. The inband DOCSIS integrated spurious emissions (see **Figure 5**) is easily met with margin.

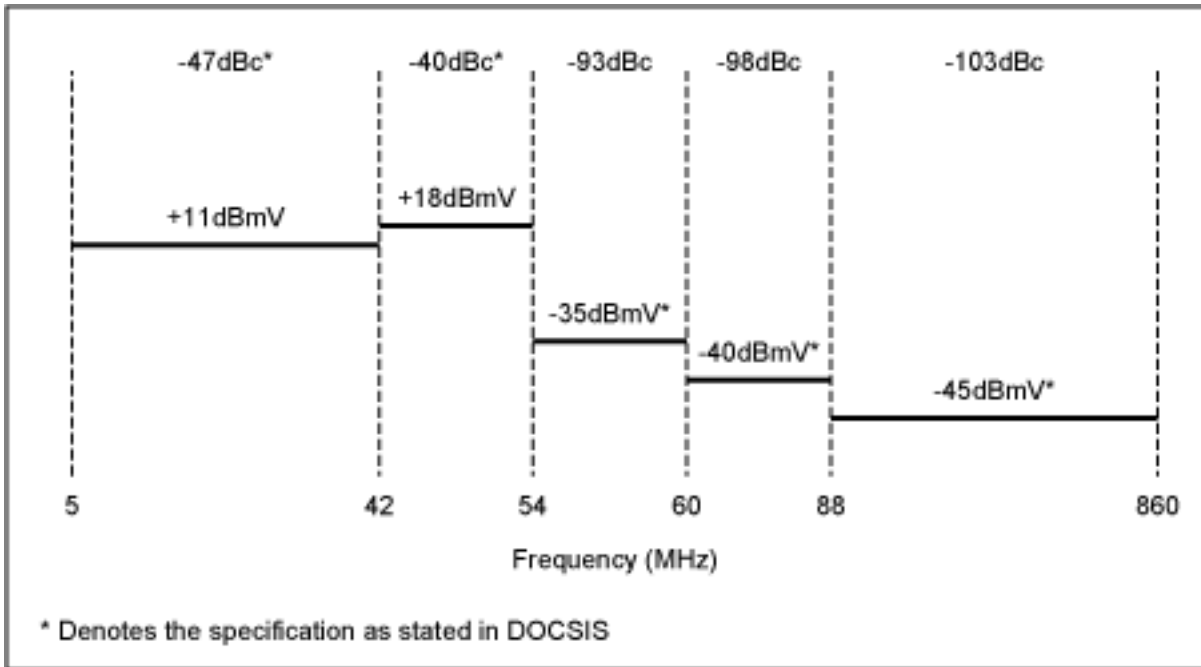

Figure 5. Integrated spurious emission limit for DOCSIS.

## MAX3509

The MAX3509 offers the functionality of the MAX3510, except that it can provide much higher output swing (+68 dBmV). Its distinguishing feature is its voltage-drive, near-zero- $\Omega$  differential output, which allows use in systems that provide external line termination (via 10dB coupler, for example). A 1:1 output transformer can be used, so this part offers the highest possible drive level from a given supply. The standby current is only 7.8mA, reducing average dissipation in power sensitive applications.

## MAX3517

The MAX3517 is essentially a MAX3514 with an external output-matching resistor. This extra degree of freedom is useful to custom tune the output transformer and diplexer source impedance properties.

## MAX3516

The MAX3516 was introduced to handle the high output power of cable telephony and digital set-tops. It is basically a MAX3514 with an additional 3dB gain and a larger thermally enhanced package 20TSSOP-EP with exposed paddle to act as thermal heat sink and enhance reliability.

## MAX3503

The MAX3503 drives 61dBmV (QPSK) into a 75 $\Omega$  load. By using a 3.3V supply a 5V regulator and associated power supply circuitry may be eliminated resulting in reduced BOM cost. Gain control is available in 0.5dB steps. The device operates over a frequency range of 5MHz to 65MHz.

## MAX3505

The MAX3505 is basically a MAX3503 designed to operate with a 5V supply. The MAX3505 has very good linearity and can deliver +64dBmV.

## MAX3507

The MAX3507 is capable of generating +63dBmV output. The on-chip anti-alias lowpass filter saves BOM cost and significant space reduction. The optional positive slope generator provides system design flexibility.

## MAX3532

The MAX3532 is not recommended for new designs. Replacements are the MAX3510, MAX3514, and MAX3516.

## Selection Guide by Market

Market	Part	Features
DOCSIS Cable Modem	MAX3510	56dB gain range, 1dB gain step, 20QSOP
EuroDOCSIS Cable Modem	MAX3514	Pin-for-pin compatible with MAX3510, 0.5dB gain step, tight gain control, 20QSOP
DOCSIS/EuroDOCSIS Cable Modem (Module)	MAX3514	Pin-for-pin compatible with MAX3510, 0.5dB gain step, tight gain control, 20QSOP
U.S. Set-Top Box	MAX3510	56dB gain range, 1dB gain step, 20QSOP
European Set-Top Box	MAX3514	Pin-for-pin compatible with MAX3510, 0.5dB gain step, tight gain control, 20QSOP
DVB Set-Top Box	MAX3516	20TSSOPP-EP
Cable Telephony (Circuit Switched)	MAX3509	68dBmV, low output impedance, 20TSSOPP-EP
Cable Telephony (Packet Switched)	MAX3514	Pin-for-pin compatible with MAX3510, 0.5dB gain step, tight gain control, 20QSOP
Open Cable Set-Top Box	MAX3516	20TSSOPP-EP
DOCSIS 2.0	MAX3503	3.3V supply, 20QFN
	MAX3505	+64dBmV, 20QFM
	MAX3507	Positive slope generator, Integrated anti-alias filter, 28QFN
	MAX3514	Industry standard, 20Q50P
	MAX3516	PHigh reliability exposed paddle 20T SSOPP-EP package

## Selection Guide by Power Performance

Power (dBmV)	Harmonics	Supply Voltage	Part
66	-56dBc 2HD, f = 33MHz Pout = +66dBmV -53dBc 3HD, f= 22MHz Pout = +66dBmV	9	MAX3509
64	-55dBc 2HD, f = 33MHz Pout = +64dBmV -50dBc 3HD, f= 22MHz Pout = +64dBmV	5	MAX3516
61	-55dBc 2HD, f = 33MHz Pout = +61dBm -55dBc 3HD, f= 22MHz Pout = +61dBmV	5	MAX3514
59	-55dBc 2HD, f = 33MHz Pout = +59dBmV -54dBc 3HD, f= 22MHz Pout = +59dBmV	5	MAX3510
63	-58dBc 2HD, f = 33MHz Pout = +63dBm -53dBc 3HD, f= 22MHz Pout = +63dBmV	5	MAX3507
64	-55dBc HD2, f = 33MHz Pout = +64dBmV -55dBc HD3, f= 22MHz Pout = +64dBmV	5	MAX3505
61	-55dBc HD2, f = 33MHz Pout = +61dBm -55dBc HD3, f= 22MHz Pout = +61dBmV	5	MAX3503

---

Application Note 780: <http://www.maxim-ic.com/an780>

### More Information

For technical questions and support: <http://www.maxim-ic.com/support>

For samples: <http://www.maxim-ic.com/samples>

Other questions and comments: <http://www.maxim-ic.com/contact>

### Related Parts

MAX3503: [QuickView](#) -- [Full \(PDF\) Data Sheet](#)

MAX3505: [QuickView](#) -- [Full \(PDF\) Data Sheet](#)

MAX3507: [QuickView](#) -- [Full \(PDF\) Data Sheet](#)

MAX3509: [QuickView](#) -- [Full \(PDF\) Data Sheet](#)

MAX3510: [QuickView](#) -- [Full \(PDF\) Data Sheet](#)

MAX3514: [QuickView](#) -- [Full \(PDF\) Data Sheet](#)

MAX3516: [QuickView](#) -- [Full \(PDF\) Data Sheet](#) -- [Free Samples](#)

MAX3517: [QuickView](#) -- [Full \(PDF\) Data Sheet](#)

AN780, AN 780, APP780, Appnote780, Appnote 780

Copyright © by Maxim Integrated Products

Additional legal notices: <http://www.maxim-ic.com/legal>