

APPLICATION NOTE 511

Using the DS1672 Low-Voltage Serial Timekeeping IC

Abstract: This application note provides an example schematic and software for the DS1672. The example software converts the 32-bit elapsed time value in the real-time clock (RTC) to year, month, date and time format. The example uses a super capacitor (super cap) to maintain the time and date when main power is absent.

Pin Assignment (Top View)

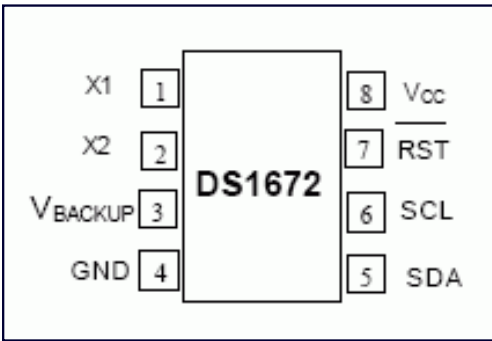

Description

The DS1672 is a low-voltage serial timekeeping IC. The DS1672 counts seconds in a 32-bit register. Using a 32-bit binary register instead of a BCD representation of the time and date, as many real-time clocks do, can be useful where time intervals are to be measured. The DS1672 operates from a low-voltage supply (2.0V, 3.0V, or 3.3V) and includes a V_{BACKUP} input, which allows the DS1672 to continue running the counter from a backup supply, such as a battery, while the main supply is off.

The DS1672 also incorporates a trickle charger. The trickle charger register uses four bits to enable the charger. Two bits are used to select one of three current-limiting resistors and two bits to select one or zero series diodes. The trickle charger circuit is capable of charging a rechargeable battery or a large capacitor. The V_{BACKUP} pin can also be connected to a nonrechargeable battery, such as a lithium coin cell. In that case, the trickle charger should not be enabled.

In this example, the DS1672 is configured to charge a capacitor connected to V_{BACKUP}.

A schematic of the circuit is shown in **Figure 1**. **Figure 2** shows the discharge voltage versus time in a typical application. Software for initializing the DS1672 and reading the registers is shown in **Figure 3**.

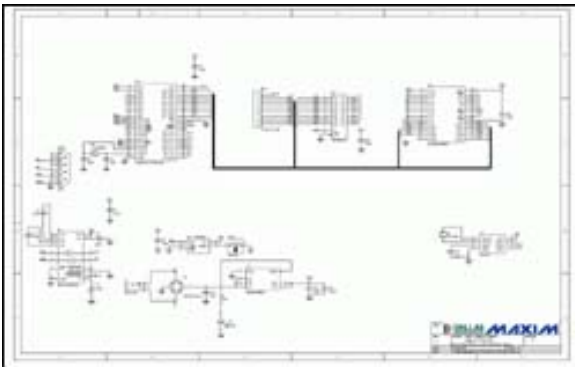

[More Detailed Image](#)

Figure 1

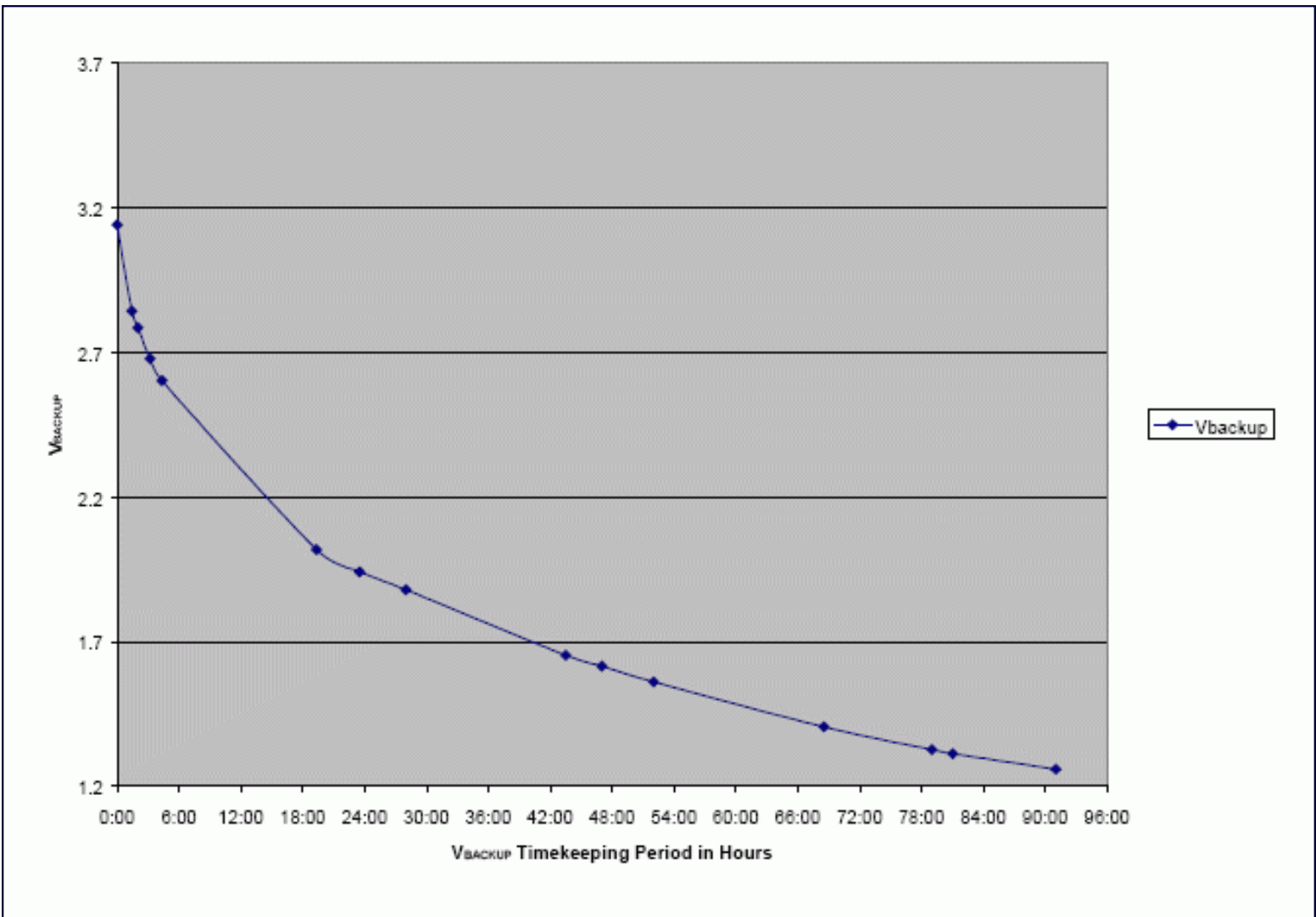

Figure 2. DS1672-3 V_{BACKUP} Timekeeping Operation with 0.1F Backup Capacitor.

Figure 3. DS1672 Initialization Software

```

/*****
/* DS1672AN.C - This file is provided to show an example of communication */
/* routines for interfacing to the DS1672. These routines are provided */
/* for example only and are not supported by Dallas Semiconductor/Maxim */
/*****/
#include <stdio.h> /* Prototypes for I/O functions */
#include <DS5000.h> /* Register declarations for DS5000 */
#define ACK 0
#define NACK 1
#define ADDRTC 0xd0 /* 2-wire addresses */
sbit scl = P1^0; /* 2-wire pin definitions */
sbit sda = P1^1;
sbit RSTb = P0^2;
void start2w();
void stop2w();
void writebyte2w(uchar d);
uchar readbyte2w(int);
void writebyte1672();
void initialize_DS1672();
void disp_clk_regs();
void en_tc();
unsigned long date2day(uint, uint, uint, uint, uint, uint);
void day2date(unsigned long);
/* global variables */
void start2w() /* ----- Initiate start condition ----- */
{
sda = 1; scl = 1;

```

```

sda = 0;
}
void stop2w() /* ----- Initiate stop condition ----- */
{
sda = 0; sda = 0;
scl = 1; scl = 1; sda = 1;
}
void writebyte2w(uchar d) /* ----- */
{
int i;
scl = 0;
for (i = 0; i < 8; i++)
{
if (d & 0x80)
sda = 1; /* Send the msbits first */
else
sda = 0;
scl = 0;
scl = 1;
d = d << 1; /* do shift here to increase scl high time */
scl = 0;
}
sda = 1; /* Release the sda line */
scl = 0;
scl = 1;
if (sda) printf("Ack bit missing %02X\n", (unsigned int)d);
scl = 0;
}
uchar readbyte2w(int b) /* ----- */
{
int i;
uchar d;
d = 0;
sda = 1; /* Let go of sda line */
scl = 0;
for (i = 0; i < 8; i++) /* read the msb first */
{
scl = 1;
d = d << 1;
d = d | (unsigned char)sda;
scl = 0;
}
sda = b; /* low for ack, high for nack */
scl = 1;
scl = 0;
sda = 1; /* Release the sda line */
return d;
}
void day2date(unsigned long x) /* ----- convert binary time to date format ---
--- */
{
int yrs = 99, mon = 99, day = 99, tmp, jday, hrs, min, sec;
unsigned long j, n;
j = x / 60; /* whole minutes since 1/1/70 */
sec = x - (60 * j); /* leftover seconds */
n = j / 60;
min = j - (60 * n);
j = n / 24;
hrs = n - (24 * j);
j = j + (365 + 366); /* whole days since 1/1/68 */
day = j / ((4 * 365) + 1);
tmp = j % ((4 * 365) + 1);
if(tmp >= (31 + 29)) /* if past 2/29 */
day++; /* add a leap day */
yrs = (j - day) / 365; /* whole years since 1968 */
jday = j - (yrs * 365) - day; /* days since 1/1 of current year */
if(tmp <= 365 && tmp >= 60) /* if past 2/29 and a leap year then */
jday++; /* add a leap day */
yrs += 1968; /* calculate year */
for(mon = 12; mon > 0; mon--)
{

```

```

switch(mon)
{
case 1: tmp = 0; break;
case 2: tmp = 31; break;
case 3: tmp = 59; break;
case 4: tmp = 90; break;
case 5: tmp = 120; break;
case 6: tmp = 151; break;
case 7: tmp = 181; break;
case 8: tmp = 212; break;
case 9: tmp = 243; break;
case 10: tmp = 273; break;
case 11: tmp = 304; break;
case 12: tmp = 334; break;
}
if((mon > 2) && !(yrs % 4)) /* adjust for leap year */
tmp++;
if(jday >= tmp) break;
}
day = jday - tmp + 1; /* calculate day in month */
printf("\n%04d %02d %02d %02d:%02d:%02d", yrs ,mon, day, hrs, min, sec);
}
/* ---- convert date to elapsed days in binary ---- */
unsigned long date2day(uint yr, uint mo, uint da, uint hrs, uint min, uint sec)
{
unsigned long x;
/* the following is broken down for clarity */
x = 365 * (yr - 1970); /* calculate number of days for previous
years */
x += (yr - 1969) >> 2; /* add a day for each leap year */
if((mo > 2) && (yr % 4 == 0)) /* add a day if current year is leap and
past Feb 29th */
x++;
switch(mo)
{
case 1: x += 0; break;
case 2: x += 31; break;
case 3: x += 59; break;
case 4: x += 90; break;
case 5: x += 120; break;
case 6: x += 151; break;
case 7: x += 181; break;
case 8: x += 212; break;
case 9: x += 243; break;
case 10: x += 273; break;
case 11: x += 304; break;
case 12: x += 334; break;
}
x += da - 1; /* finally, add the days into the
current month */
x = x * 86400; /* and calculate the number of seconds in
all those days */
x += (hrs * 1800); /* add the number of seconds in the hours
*/
x += (hrs * 1800); /* add the number of seconds in the hours
*/
x += (min * 60); /* ditto the minutes */
x += sec; /* finally, the seconds */
return(x);
}
void writebyte1672() /* ----- */
{
uchar Add;
uchar Data;
/* Get Address & Data */
printf("\nEnter the Read Address\nADDRESS:");
scanf("%bx", &Add);
printf("\nDATA:");
scanf("%bx", &Data);
start2w();
writebyte2w(ADDRTC);
}

```

```

writebyte2w(Add);
writebyte2w(Data);
stop2w();
}
void initialize_DS1672() /* ----- */
/* Note: NO error checking is done on the user entries! */
{
uchar a, b, c, d;
uint yr, mn, dt, dy, hr, min, sec, day;
unsigned long y;
start2w();
writebyte2w(ADDRTC);
writebyte2w(0x04);
writebyte2w(0x00); /* enable the oscillator */
stop2w();
printf("\nEnter the year (1970-2099): ");
scanf("%d", &yr);
printf("\nEnter the month (1-12): ");
scanf("%d", &mn);
printf("\nEnter the date (1-31): ");
scanf("%d", &dt);
/* printf("\nEnter the day (1-7): "); */
/* scanf("%d", &dy); */
printf("\nEnter the hour (1-24): ");
scanf("%d", &hr);
printf("\nEnter the minute (0-59): ");
scanf("%d", &min);
printf("\nEnter the second (0-59): ");
scanf("%d", &sec);
y = date2day(yr, mn, dt, hr, min, sec);
a = (y & 0xff);
b = ((y >> 8) & 0xff);
c = ((y >> 16) & 0xff);
d = ((y >> 24) & 0xff);
start2w();
writebyte2w(ADDRTC); /* write slave address, write 1672 */
writebyte2w(0x00); /* write register address, 1st clock register */
writebyte2w(a);
writebyte2w(b);
writebyte2w(c);
writebyte2w(d);
stop2w();
}
void disp_clk_regs() /* ----- */
{
uchar reg1, prv_sec = 99, reg2, reg3, reg4;
unsigned long z;
while(!RI) /* Read & Display Clock Registers */
start2w();
writebyte2w(ADDRTC); /* write slave address, write 1672 */
writebyte2w(0x00); /* write register address, 1st clock register */
start2w();
writebyte2w(ADDRTC | 1); /* write slave address, read 1672 */
reg1 = readbyte2w(ACK); /* starts w/last address stored in register pointer */
reg2 = readbyte2w(ACK);
reg3 = readbyte2w(ACK);
reg4 = readbyte2w(NACK);
stop2w();
if(reg1 != prv_sec) /* display every time seconds change */
{
z = reg4;
z <<= 8;
z += reg3;
z <<= 8;
z += reg2;
z <<= 8;
z += reg1;
day2date(z);
}
prv_sec = reg1;
}

```

```

RI = 0; /* Swallow keypress to exit loop */
}
void en_tc(dat) /* ----- enable the trickle-charger ----- */
{
start2w();
writebyte2w(ADDRTC);
writebyte2w(5);
writebyte2w(dat); /* enable the trickle-charger */
stop2w();
}
main (void) /* ----- */
{
uchar i, M, M1;
RSTb = 1;
while (1)
{
printf("\nDS1672\n");
printf("I Init DS1672 D/E Disable/Enable TC\n");
printf("R Read Time W Write Byte\n");
printf("\nEnter Menu Selection:");
M = _getkey();
switch(M)
{
case 'R':
case 'r': disp_clk_regs(); break;
case 'W':
case 'w': writebyte1672(); break;
case 'D':
case 'd': en_tc(0); break;
case 'E':
case 'e': en_tc(0xa6); break;
case 'I':
case 'i': initialize_DS1672(); break;
}
}
}
}

```

Application Note 511: <http://www.maxim-ic.com/an511>

More Information

For technical questions and support: <http://www.maxim-ic.com/support>

For samples: <http://www.maxim-ic.com/samples>

Other questions and comments: <http://www.maxim-ic.com/contact>

Related Parts

DS1371: [QuickView](#) -- [Full \(PDF\) Data Sheet](#) -- [Free Samples](#)

DS1374: [QuickView](#) -- [Full \(PDF\) Data Sheet](#)

DS1672: [QuickView](#) -- [Full \(PDF\) Data Sheet](#) -- [Free Samples](#)

AN511, AN 511, APP511, Appnote511, Appnote 511

Copyright © by Maxim Integrated Products

Additional legal notices: <http://www.maxim-ic.com/legal>