

APPLICATION NOTE 4224

Using the DS2786 Battery Fuel Gauge in the Host Side of a 2-Cell Battery Application

Abstract: The DS2786 stand-alone, open-circuit-voltage (OCV) based fuel gauge has an operating range designed for a 1-cell lithium-ion (Li+) battery pack. However, the DS2786 can also be used in a 2-cell application by adding a few extra components to the typical application circuit. This application note details a circuit for using the DS2786 on the host side of a 2-cell Li+ battery pack.

Overview

The DS2786 stand-alone, open-circuit-voltage (OCV) based fuel gauge estimates available capacity for lithium-ion (Li+) and lithium polymer (Li+-Poly) batteries based on the cell voltage in an open-circuit state following a relaxation period. The OCV is used to determine relative cell capacity based on a lookup table stored in the IC. This capability makes accurate capacity information available immediately after a battery pack is inserted.

While the DS2786's operating range is designed for use in a 1-cell Li+ battery system, it can also be used in a 2-cell system. This application note details a circuit that only requires one additional IC to utilize the DS2786 on the host side of a 2-cell system. This circuit allows the use of all the DS2786's features, including on-chip voltage, current, and temperature measurement; two auxiliary voltage inputs; and a two-wire interface.

Circuit Description

Figure 1 illustrates a circuit for using the DS2786 in the host system of a 2-cell battery application. The schematic shown includes one additional IC—a low-dropout (LDO) linear regulator—and some discrete components with the standard DS2786 circuit.

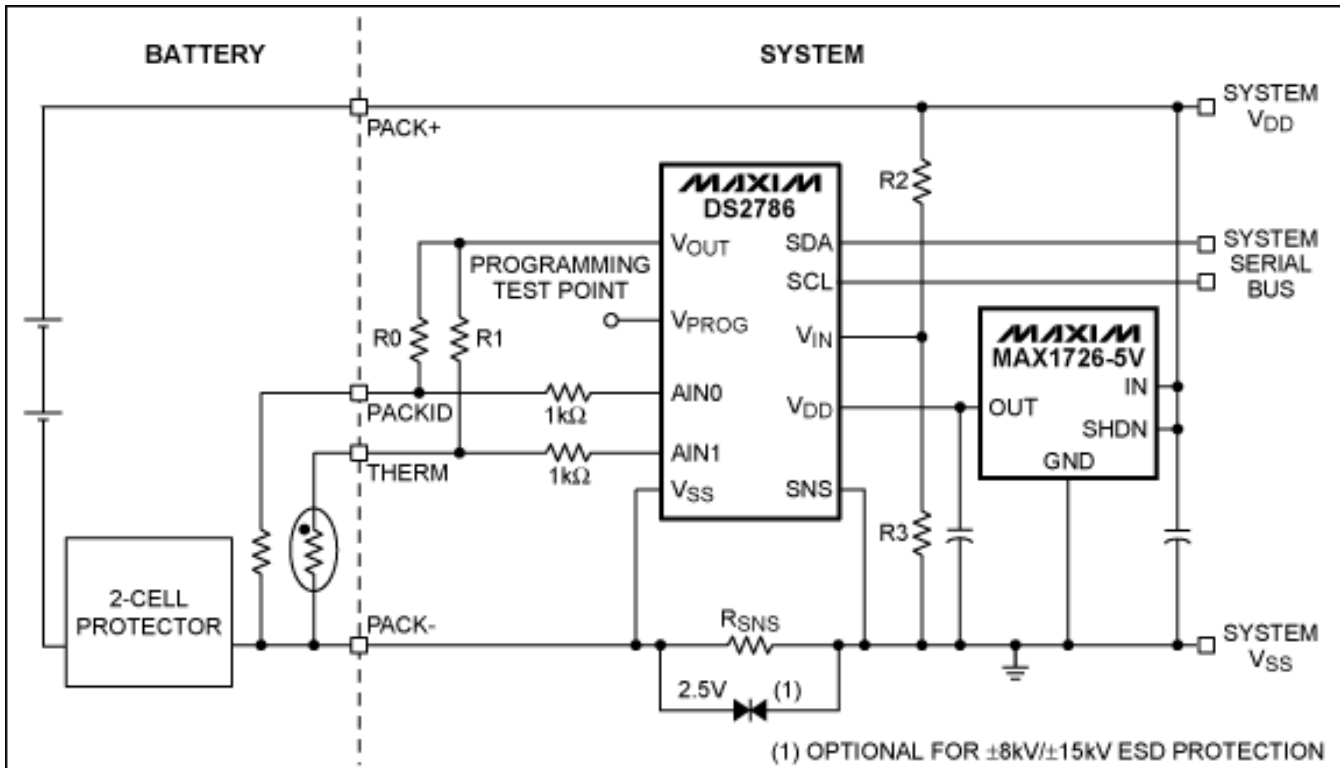

Figure 1. The DS2786 on the host side of a 2-cell Li+/Li-Poly application.

Because the 2-cell battery pack's voltage exceeds the maximum operating voltage of the DS2786's V_{DD} pin, a low-power regulator

is necessary to supply V_{DD} with an acceptable voltage. The example circuit uses a MAX1726EUK5 LDO to provide the regulated voltage. This regulator has a typical operating current of $2\mu A$ and a shutdown mode current draw of only $0.7\mu A$, thus making it ideal for battery-powered applications. The 5V version of the LDO is used to ensure that the voltage on the DS2786's V_{DD} pin remains greater than the V_{IN} pin. The capacitors on the input and output of the LDO are recommended for stability. If a different LDO is used, the voltage at the V_{DD} pin should remain above V_{IN} for all cases.

The 2-cell pack voltage must also be reduced to an acceptable level for the V_{IN} pin. Resistors R2 and R3 produce a voltage divider that can be used to easily divide the pack voltage by two. With this method, the V_{IN} pin measures half of the total pack voltage.

Although not necessary for battery fuel gauging, the example circuit is shown with V_{OUT} driving two voltage-divider circuits.

Resistor R0 and the pack identification resistor provide a voltage source for AIN0 and a method to identify different packs. Resistor R1 and the thermistor provide a voltage source for AIN1 and a method to measure the pack temperature. V_{OUT} , AIN0, and AIN1 can be used for any other purpose, or not used at all.

Considerations

The DS2786 provides battery-pack capacity estimates based on the open-circuit voltage presented at the V_{IN} pin. Because the circuit in Figure 1 only measures half of the pack voltage, the voltage-based capacity lookup table stored in the DS2786's EEPROM must be modified appropriately. The voltage and capacity values obtained by characterizing the battery pack should be stored in EEPROM with the voltage level divided by 2. For example, if the battery pack has a capacity of 80% at 8V, the stored value should be 80% at 4V.

The voltage divider formed by resistors R2 and R3 challenges the system designer to minimize battery load, yet still maintain accurate voltage measurements at V_{IN} . Increasing the resistor values decreases current draw, but increases the voltage error caused by the input resistance (R_{IN}) of V_{IN} . Three example resistor values are shown in **Table 1**, along with the current load and worst-case voltage error calculations. The lookup table values shown for cell capacity and voltage are the default values given with the DS2786. For all cases, the measurement error is greatest from approximately 3.67V to 4V, where the cell voltage discharge curve remains fairly flat. Table 1 only considers the measurement errors due to the worst-case value of R_{IN} (minimum $15M\Omega$) in parallel with R2 and R3. Other errors could arise from R2 to R3 resistor differences, and it is recommended that R2 and R3 always be populated from the same resistor lot.

Table 1. Error Calculations for Different Voltage Divider Values

					R2 = R3 = 50k Ω , R _{IN} = 15M Ω			R2 = R3 = 100k Ω , R _{IN} = 15M Ω			R2 = R3 = 200k Ω , R _{IN} = 15M Ω		
					$V_{IN} R_{Thevenin}$ 24958.403			$V_{IN} R_{Thevenin}$ 49833.889			$V_{IN} R_{Thevenin}$ 99337.748		
DS2786 Default Lookup Table Values					Voltage Measurement Error 0.00166389			Voltage Measurement Error 0.00332226			Voltage Measurement Error 0.00662252		
Capacity (%)	Cell Voltage (V)	Δ Capacity (%)	Δ Voltage (mV)	Δ Capacity/ Δ Voltage	Max V_{IN} Error (mV)	Max Capacity Error (%)	Max Current (μA)	Max V_{IN} Error (mV)	Max Capacity Error (%)	Max Current (μA)	Max V_{IN} Error (mV)	Max Capacity Error (%)	Max Current (μA)
100	4.17114	9.5	84.23	0.11279	6.94	0.78	83.42	13.86	1.56	41.71	27.62	3.12	20.86
90.5	4.08691	5.5	45.17	0.12177	6.80	0.83	81.74	13.58	1.65	40.87	27.07	3.30	20.43
85	4.04175	5	36.62	0.13653	6.73	0.92	80.83	13.43	1.83	40.42	26.77	3.65	20.21
80	4.00513	27.5	174.56	0.15754	6.66	1.05	80.10	13.31	2.10	40.05	26.52	4.18	20.03
52.5	3.83057	27.5	78.13	0.35200	6.37	2.24	76.61	12.73	4.48	38.31	25.37	8.93	19.15
25	3.75244	15	79.35	0.18905	6.24	1.18	75.05	12.47	2.36	37.52	24.85	4.70	18.76
10	3.67310	5	53.71	0.09309	6.11	0.57	73.46	12.20	1.14	36.73	24.33	2.26	18.37
5	3.61938	5	433.35	0.01154	6.02	0.07	72.39	12.02	0.14	36.19	23.97	0.28	18.10
0	3.18604												

Summary

The DS2786 is designed for a 1-cell Li+ battery pack, but can easily be adapted to provide fuel-gauge data on the host side of

a 2-cell application. The circuit described in this article includes only one additional IC and some discrete components with the standard DS2786 circuit so that it may operate within a 2-cell application. By implementing the described circuit, the 2-cell application is able to use all of the features of the DS2786 for stand-alone, OCV-based fuel gauging.

Application Note 4224: www.maxim-ic.com/an4224

More Information

For technical support: www.maxim-ic.com/support

For samples: www.maxim-ic.com/samples

Other questions and comments: www.maxim-ic.com/contact

Automatic Updates

Would you like to be automatically notified when new application notes are published in your areas of interest? [Sign up for EE-Mail.](#)

Related Parts

DS2786: [QuickView](#) -- [Full \(PDF\) Data Sheet](#) -- [Free Samples](#)

AN4224, AN 4224, APP4224, Appnote4224, Appnote 4224

Copyright © by Maxim Integrated Products

Additional legal notices: www.maxim-ic.com/legal