



APPLICATION NOTE 4181

# Simplify the Design of 1-Cell Li+ Battery-Operated Devices

By: Mehdy Khotan

*Abstract: The MAX8671X power-management IC (PMIC) charges lithium batteries and regulates power for portable-system designs. To charge a lithium-ion (Li+) lithium polymer (Li-Poly) battery, this device uses input power from either a USB port or an external AC-to-DC power adapter. The PMIC also integrates many power-management features including overvoltage protection power switches for the USB and DC inputs, and five independent on-chip regulators for system power.*

Low cost, small size, and light weight are all requirements for today's portable electronic systems. Ideal for systems that incorporate battery charging and regulated power for various on-board subsystems, the [MAX8671X](#) power-management IC (PMIC) delivers all of the features needed for a portable-system design. The device receives charging power for a lithium-ion (Li+) or lithium polymer (Li-Poly) battery from either a USB port or an external AC adapter. In addition to battery charging, the PMIC integrates overvoltage-protection power switches for the USB and DC inputs, as well as five independent on-chip regulators for system power. This combination of features dramatically reduces component count on cramped circuit boards (**Figure 1**), making the device particularly well suited for small portable devices such as smartphones, PDAs, portable media players, GPS navigation devices, digital still cameras, and digital video cameras.

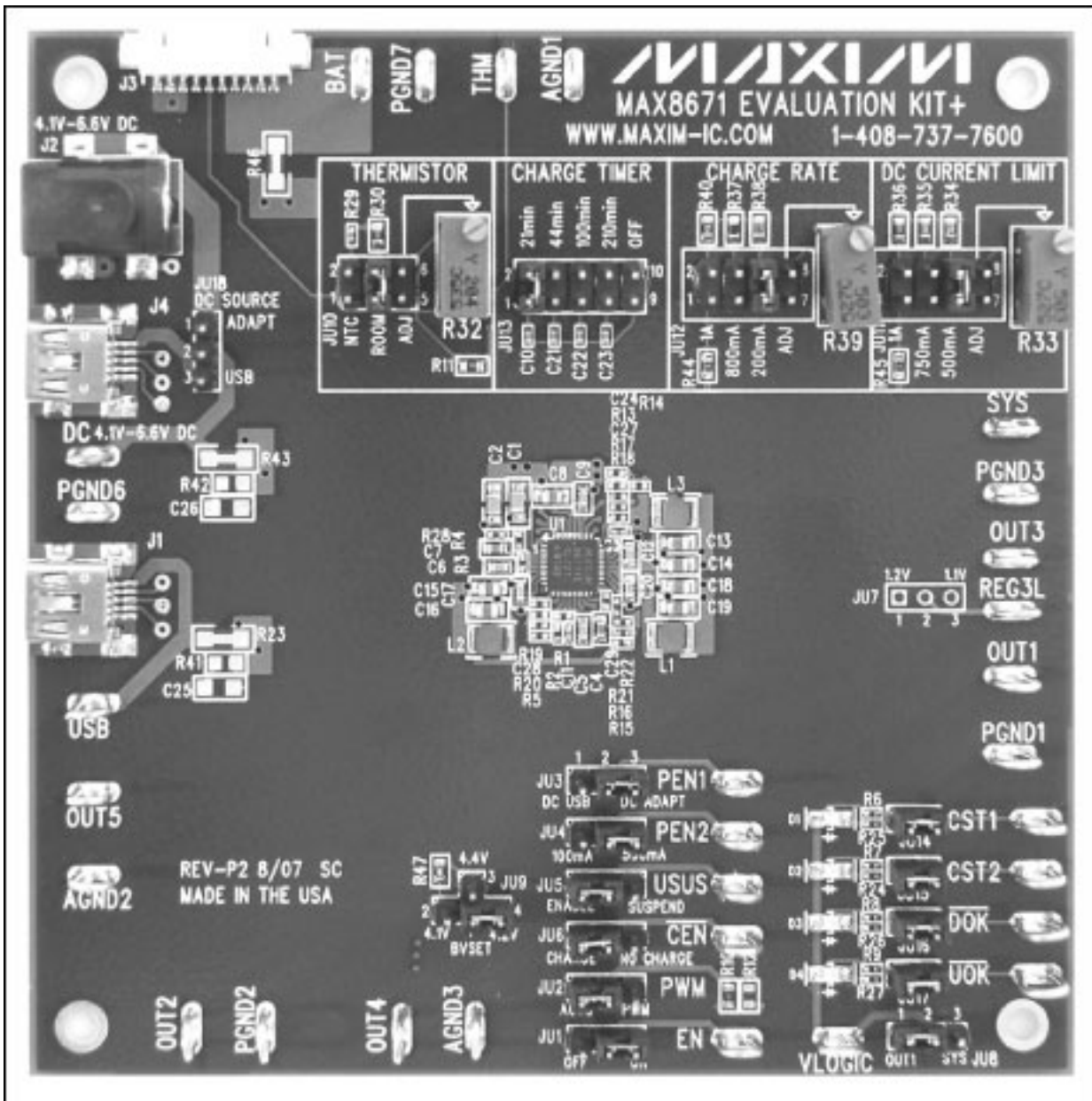

Figure 1. This MAX8671X evaluation board photo shows a compact PCB layout for a typical application circuit.

Because the MAX8671X seamlessly manages USB and AC-adapter power sources, it allows manufacturers to eliminate the AC-to-DC wall charger as part of a handheld device's retail package. Retail package size and weight are consequently reduced, along with distribution costs. A product could then be shipped with only a USB cable for charging from a computer's USB port while syncing or transferring data, with the AC adapter as an aftermarket option.

A full array of functions is integrated into the MAX8671X: battery charging, adapter-USB-battery switchover, system-voltage regulation, and various monitoring functions. These functions, as seen in **Figure 2**, make this PMIC ideal for a wide variety of applications. Five independent, integrated voltage regulators (three 2MHz switch-mode step-down regulators with up to 96% efficiency and two low-quiescent-current linear regulators) efficiently supply power to multiple subsystems.

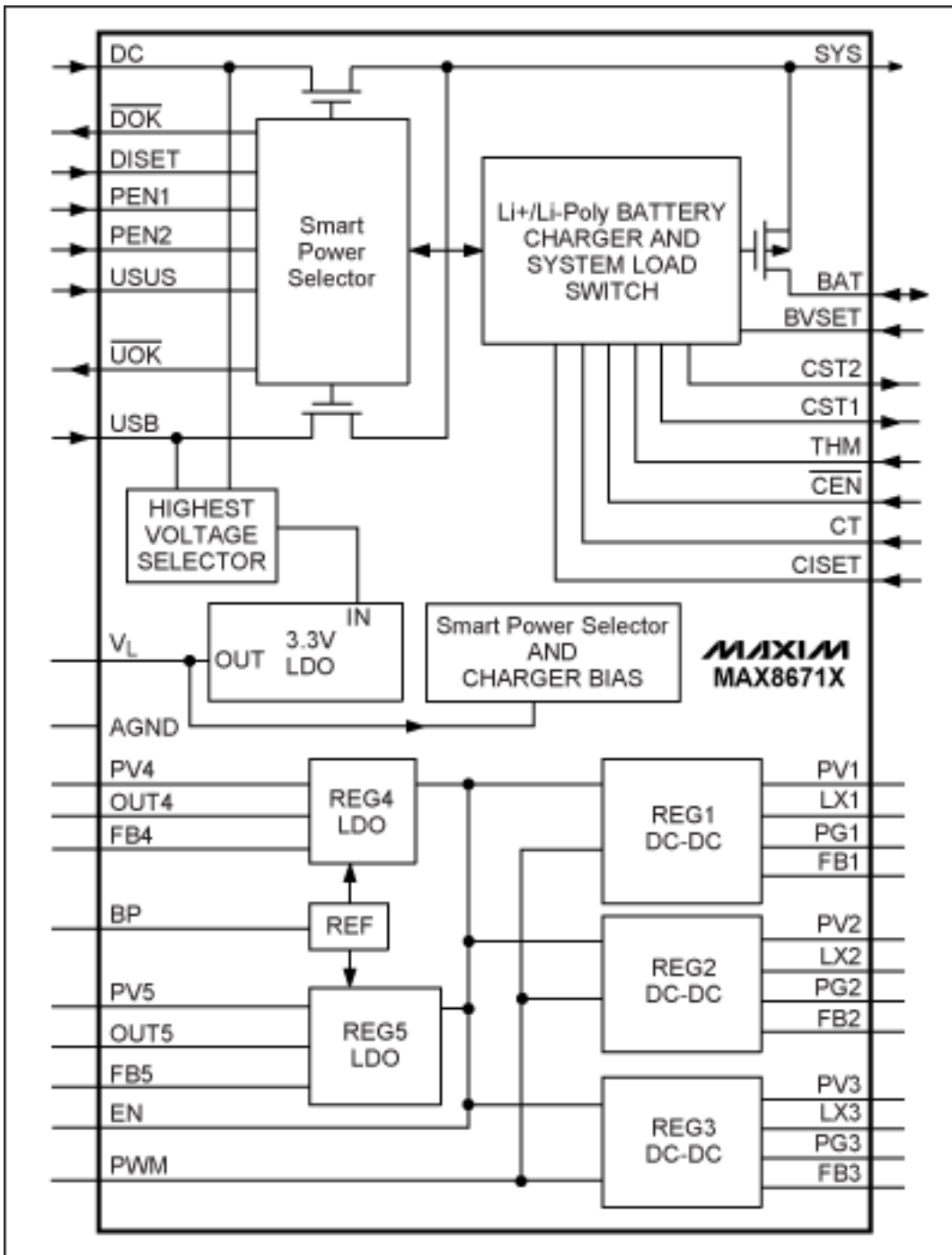

Figure 2. Five independent regulators, plus all battery charging functions and power selection switches, are integrated within the MAX8671X PMIC. Power can be supplied through either an AC adapter or a USB cable.

## Integration Reduces Power Switchover Clutter

Integrated within the MAX8671X PMIC are all of the power switches required for DC/USB input overvoltage protection, single-cell Li+ battery charging, and load switching between the battery and external power. These integrated switches and regulators eliminate the need for external MOSFETs and the clutter of voltage detectors, current-sense resistors, comparators, timers, and other discrete components that is found so often in power monitoring and switchover circuitry. The resulting component-count and board-space reductions translate to lower cost and a more compact system.

The MAX8671X Smart Power Selector™ seamlessly distributes power between external inputs, the battery, and the system load (see **Figure 3**). The selector performs the following operations:

1. When both an external power supply (USB or AC adapter) and battery are connected, if the system (SYS) load current is less than the selected input-current limit, the battery is charged with any available current not used by the system. When the system load exceeds the input-current limit, the battery supplies supplemental current to the load to maintain the SYS load current ( $I_{SYS}$ ) and prevent a reset.
2. When the battery is connected and there is no external power, the system is powered from the battery.
3. When external power is connected and there is no battery, the system is powered from the external power input.

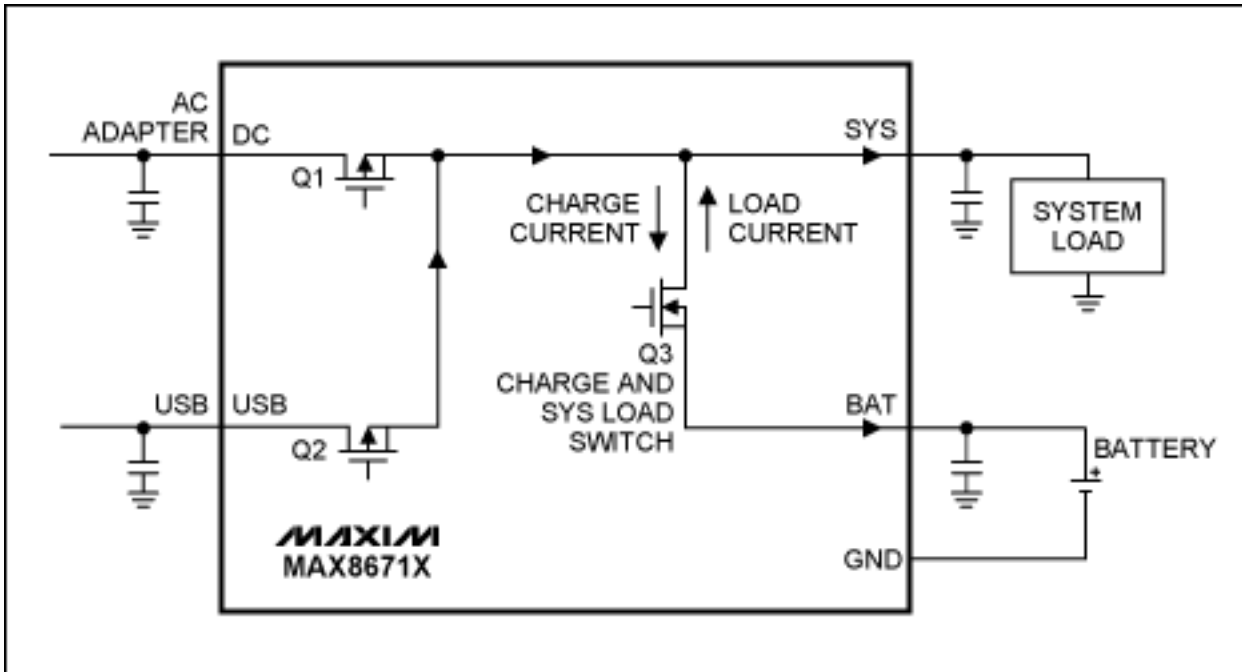

Figure 3. The Smart Power Selector leverages an integrated power-switch MOSFET (Q3), which acts as the load switch and the charging switch.

In some instances, there may not be enough adapter or USB current to supply peak system loads. To deal with this, an integrated MOSFET with a low  $R_{DS(ON)}$  internally routes the battery to the SYS pin to power the load when system load peaks exceed the selected input-current limit, or when no power source is available at either the DC or USB inputs. If the system load continuously exceeds the input-current limit, the battery will not charge, even when external power is connected. This condition does not last long in most cases, as high loads usually occur only in short peaks. During these peaks, battery energy supports the system; at all other times, the battery charges.

In addition to charging the battery, the MAX8671X also supplies power to the system through the SYS output and multiple on-chip regulators. The IC is designed so that charging current is also provided from SYS node. Therefore, the selected input-current limit controls the *total* SYS current (i.e., the sum of the  $I_{SYS}$  and the battery-charging current).

SYS can be powered from either the DC or USB input pin (or from the battery, if no external power is connected). If both the DC and USB sources are connected, the DC input takes precedence. Designers also have the option of using the MAX8671X with separate inputs for USB and AC-adapter power, or with a single input that accepts both. Logic inputs, PEN1 and PEN2, select the correct current limits for dual-input or single-input operation. The DC input's current limit is adjustable up to 1A, and both the DC and USB inputs support 100mA, 500mA, and USB-suspend modes.

## Designing Regulators for Long Battery Life

The high efficiency of the MAX8671X's five on-chip regulators minimizes power losses, thus maximizing battery life. In addition to delivering high efficiency when running with heavy loads, the regulators also operate efficiently when lightly loaded. This further improves battery life, as subsystem functions may have peak loads of several hundred milliamps; however, most of the time, they demand much less than that. In such systems,

optimizing efficiency for the load current that is drawn most often, rather than for the highest load, provides the most benefit for battery life.

Many portable systems spend most of their life in "sleep" states. Thus, regulators that are highly efficient at a full load (> 90%), but much less efficient when idling (< 60%), will drain the battery faster than regulators that maintain a high efficiency when lightly loaded. The MAX8671X's regulators address this issue by delivering up to 96% efficiency in the upper load range (delivering up to 425mA to the system loads), while still maintaining up to 85% efficiency with only a 1mA load.

Each of the three adjustable switching regulators (REG1, REG2, and REG3) can supply up to 425mA. They operate at a switching frequency of 2MHz, which helps to minimize inductor and capacitor size. External resistors set each regulator's output voltage.

The remaining regulators (REG4 and REG5) are low-dropout (LDO) linear regulators that supply up to 150mA. REG5 powers the system's USB transceiver circuitry and is only active when USB power is available. REG4 is powered from the battery when no power is available from the DC or USB sources. These two LDOs improve battery life, give system designers more flexibility, and provide additional power savings due to their wide, 1.7V to 5.5V input-voltage range. The 1.7V minimum input voltage allows these LDOs to be powered from one of the step-down DC-DC converter outputs rather than from the battery directly.

## Internal Charger Manages the Battery

The dual-input charger portion of the PMIC accepts either a USB power source or the output of an AC adapter. It performs all power control and charging functions due to the integrated Smart Power Selector technology and the state-control logic that manages the charge cycle, as shown by the charging curve in **Figure 4**. Charge current is adjustable up to 1A to support a wide range of battery capacities.

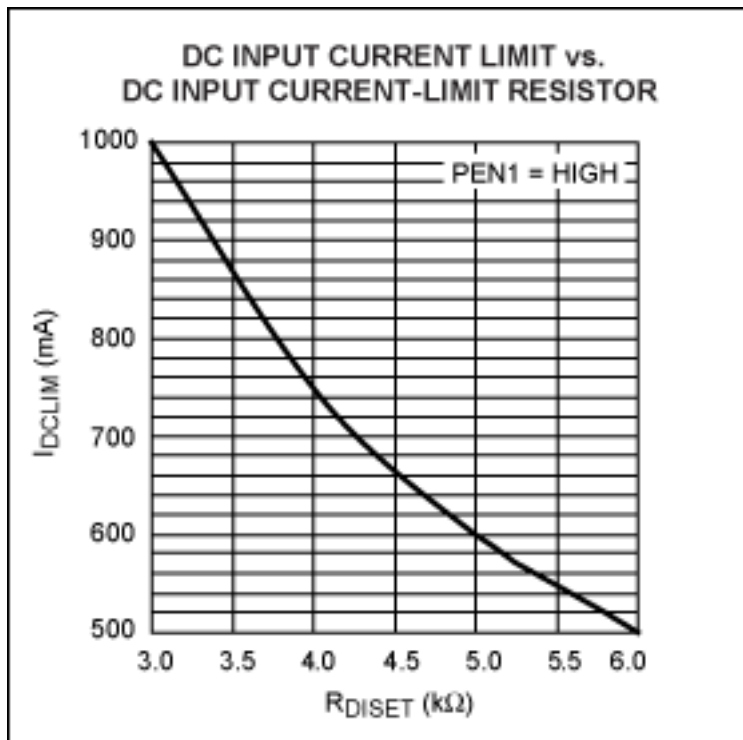

Figure 4. An internal state controller manages the Li+ battery cell charging and delivers the voltage and current needed to safely charge the battery.

With a valid DC and/or USB input, the battery charger initiates a charge cycle when the charger is enabled. It first checks battery voltage to see if the battery is deeply discharged to less than the prequalification threshold (3.0V). If it is, the charger enters a safety precharge mode in which the battery charges at 1/10th the set fast-charge current. Once the battery voltage rises above 3.0V, the charger proceeds to fast-charge mode and applies the set charge current.

As charging continues, the battery voltage rises until it approaches the battery regulation voltage (selected with

the BVSET pin); at this point, the charge current begins to taper down. When the charge current decreases to 4% of the set fast-charge current, the charger enters a brief top-off state, and then charging stops. If, after charging stops, the battery voltage subsequently drops 120mV below the battery regulation voltage, charging restarts and the timers reset. This ensures that a battery is maintained at, or at least very close to, full charge at all times without risking overcharge.

The charge rate is determined by several factors: the battery voltage, the USB/DC input-current limit, the charge-setting resistor ( $R_{CISET}$ ), the  $I_{SYS}$ , and the die temperature. The MAX8671X automatically reduces the charge current to a value below the set charge rate to prevent both input overload and overheating.

## Taking Power from the USB Port

The USB pin on the MAX8671X is a current-limited power input that supplies the SYS pin with up to 500mA. The current-limited switch that connects USB to SYS is also a linear regulator designed to operate in dropout. This linear regulator prevents the SYS voltage from exceeding 5.3V, even under USB input fault conditions up to 14V.

In application, the USB pin is typically connected to the  $V_{BUS}$  line of the USB interface. It can be set to one of three current limits to support USB current-limit specifications by means of the second power-enable (PEN2) and USB-suspend (USUS) digital-control inputs. The limits are 100mA for low-power USB mode, 500mA for high-power USB mode, and 0.11mA (typ) for USB suspend and unconfigured on-the-go (OTG) mode.

When the USB input voltage is below the undervoltage threshold ( $V_{USBL}$ : 4V, typ) or below the battery voltage, it is considered invalid and is turned off. Similarly, the USB input voltage is also turned off if it is above the overvoltage threshold ( $V_{USBH}$ : 6.9V, typ).

To comply with the Hi-Speed USB specification, each connected device must be initially configured for low power. After USB enumeration, the device can switch from low power to high power if given permission from the USB host. The MAX8671X does not perform enumeration, but instead relies on the system to communicate with the USB host. The host decides on the appropriate current limit, and sends commands to the MAX8671X through its PEN1, PEN2, and USUS inputs.

## On-Chip Thermal Management

The MAX8671X includes thermal-management features to prevent heat rise, even under suboptimal thermal conditions that are common in very small handheld devices. It reduces input current by 5%/°C when the die temperature exceeds +100°C. Under all conditions, the  $I_{SYS}$  has priority over the charger current, so input current is first reduced by decreasing the charge current. If the junction temperature still reaches +120°C in spite of the charge-current reduction, no input current is drawn and the battery supplies the system load. This on-chip thermal-limiting circuitry is not related to, and operates independently from, the thermistor input (THM), which (typically) uses an external thermistor to monitor the battery.

## A Complete PMIC

Besides integrating the key power-management functions required in battery-powered portables—charging, power switchover, and system regulation—the MAX8671X also reduces the discrete components circuitry commonly found in these designs. By including features like thermal regulation, overvoltage protection, charge-status and fault outputs, power-OK monitors, battery thermistor monitor, and charge timers, it reduces cost by eliminating the need for extra logic and switching components; more importantly, it additionally saves design time. System and battery safety and reliability are also improved because Maxim's integrated hardware solution means that a system software problem cannot impact charging or power management.

A thermally-enhanced, space-saving, 5mm x 5mm, 40-pin TQFN package houses the MAX8671X. This package allows the device to fit into many of today's space-limited portable products. Additionally, this PMIC can operate over an extended temperature range (-40°C to +85°C), which makes it ideal for many industrial applications.

A similar article appeared in the October 2007 issue of the *EDN Power Supplement*.

Smart Power Selector is a trademark of Maxim Integrated Products, Inc.

---

Application Note 4181: [www.maxim-ic.com/an4181](http://www.maxim-ic.com/an4181)

#### **More Information**

For technical support: [www.maxim-ic.com/support](http://www.maxim-ic.com/support)

For samples: [www.maxim-ic.com/samples](http://www.maxim-ic.com/samples)

Other questions and comments: [www.maxim-ic.com/contact](http://www.maxim-ic.com/contact)

---

#### **Automatic Updates**

Would you like to be automatically notified when new application notes are published in your areas of interest?

[Sign up for EE-Mail.](#)

---

#### **Related Parts**

MAX8671X: [QuickView](#) -- [Full \(PDF\) Data Sheet](#) -- [Free Samples](#)

AN4181, AN 4181, APP4181, Appnote4181, Appnote 4181

Copyright © by Maxim Integrated Products

Additional legal notices: [www.maxim-ic.com/legal](http://www.maxim-ic.com/legal)