

APPLICATION NOTE 4038

Optimizing Ultrasound-Receiver VGA Output-Referred Noise and Gain: Improves Doppler Dynamic Range and Sensitivity

Abstract: A critical component in phased-array ultrasound receivers is the variable-gain amplifier (VGA), sometimes referred to as a time-gain control (TGC) amplifier. In this article, we examine how VGA output-referred noise and gain can have a pronounced effect on ultrasound pulsed Doppler dynamic range and sensitivity, and how the MAX2037 octal ultrasound VGA has optimized these parameters to yield the best overall system performance in a typical receiver lineup.

This article was also featured in [Maxim's Engineering Journal, vol. 60](#) (PDF, 386kB).

Phased-Array Receiver Overview

Before we examine how these critical VGA specifications affect Doppler performance, it is helpful to review the basic elements and operation of a typical phased-array ultrasound receive channel. For a high-level overview of phased-array ultrasound receivers, see *Appendix A—Phased-Array Ultrasound System Basics*. A typical receiver lineup consists of an LNA, a VGA, an anti-alias filter, and an ADC (as shown in **Figure 1**). The LNA amplifies single-ended input signals between 1MHz and 15MHz from a single transducer element. The LNA has approximately 19dB of gain and an active input impedance of between 50Ω and 1kΩ, optimized to match the transducer element and maintain an ultra-low noise figure.

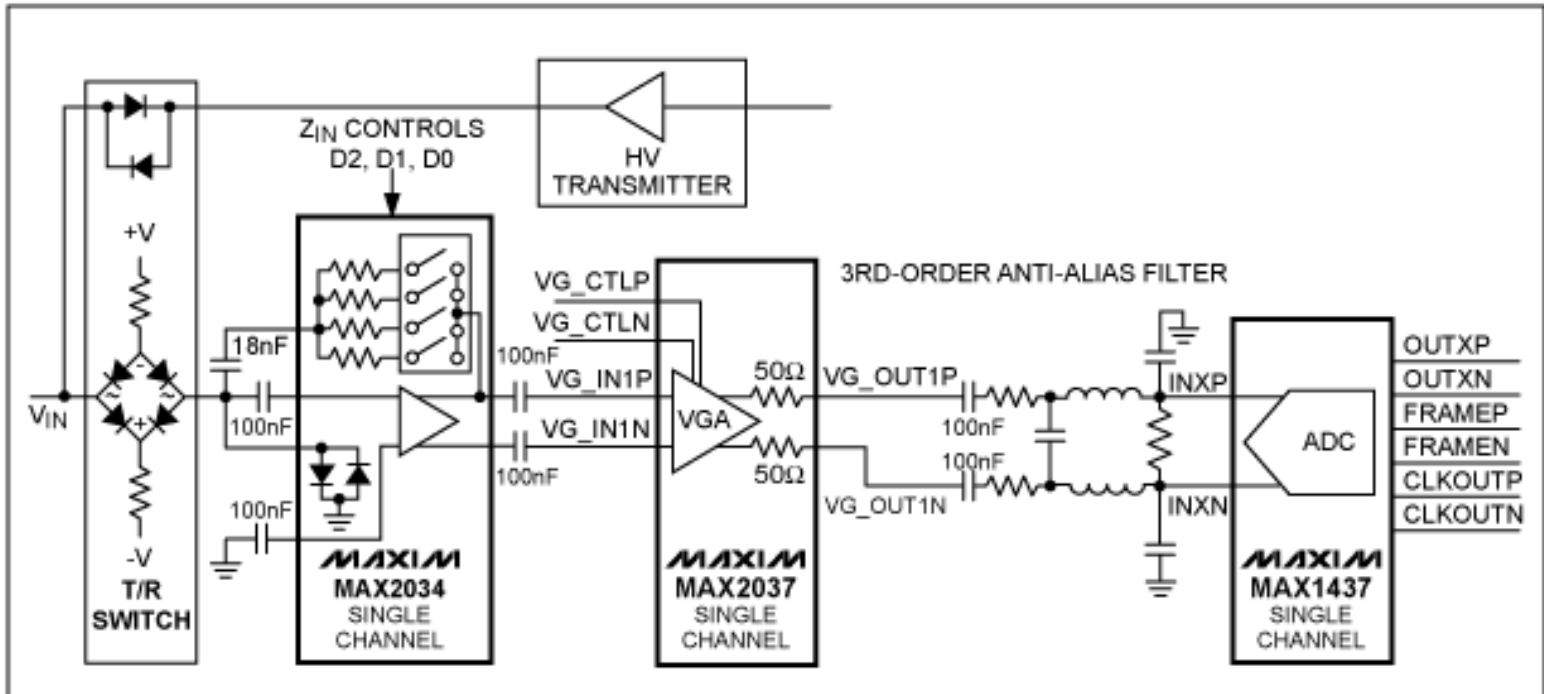

Figure 1. A typical phased-array ultrasound-receiver lineup consists of an LNA, a VGA, an anti-alias filter, and an ADC.

At the beginning of a receive cycle immediately after a transmit burst, the signal at the LNA input can be as large as $0.5V_{p-p}$. Over the receive interval, the signal strength attenuates and ultimately falls below the noise floor of the receiver. The rate of attenuation can be calculated knowing that acoustic energy attenuates in the human body at a rate of approximately 0.7dB/cm-MHz (1.4dB/cm-MHz, round trip) and that the propagation velocity of sound in the body is 1540m/s (13μs, round trip). The dynamic range required to process this signal over the full receive interval is

approximately 110dB and is well beyond the range of a realistic ADC converter. As a result, the receiver gain is dynamically increased over the receive interval using a VGA (hence the term "time-gain control") to map this signal into the available ADC input dynamic range. A VGA with approximately 40dB of gain range is required to map the received signal into a 12-bit ADC with 70dB of dynamic range. The three-pole anti-alias filter in the Figure 1 receive chain keeps the ADC from mapping high-frequency noise and extraneous signals beyond the normal maximum imaging frequencies of 15MHz. The ADC is typically a 12-bit ADC running at anywhere from 40Msps to 60Msps.

VGA Output-Referred Noise and Gain, and Its Affect on PW Doppler

Standard 2D, grayscale ultrasound imaging typically requires about 40dB of dynamic range per phased-array channel. However, pulsed Doppler imaging modalities, such as spectral PW Doppler and color-flow imaging, require as much as 70dB because the received signal strength from blood can be substantially weaker than signals from surrounding tissue. For this reason, high-dynamic-range 12-bit ADCs are used to improve receiver Doppler performance.

Designing VGAs compatible with these ADCs in an ultrasound receiver lineup is a significant challenge. Specifically, it is difficult to maintain low output-referred noise to preserve receiver dynamic range while still providing enough gain to ensure that a low receiver noise figure is maintained at high-TGC levels. Low output-referred noise and high maximum gain generally are mutually exclusive benefits in practical VGA implementations. Designers of VGAs for this application must optimize and properly balance these VGA properties to ensure the best overall receiver performance.

To better understand how these VGA properties affect the performance of the receiver, let us consider two specific cases. One situation is when the TGCs are at medium and low gains and the received signal levels are relatively large. Under these conditions, it is important to optimize receiver dynamic range. The other case is when the TGCs are at maximum gain and the signal levels are small. In the latter case, preserving sensitivity by optimizing receiver noise figure is paramount.

Effect of VGA Output-Referred Noise on Receiver Dynamic Range (Medium- to Low-TGC Gain Condition)

At medium- and low-TGC levels, the VGA output noise is dominated by the output-referred noise of the VGA. This noise must be significantly below the ADC's noise floor, otherwise the ADC's dynamic range is sacrificed. Consider the ultrasound receiver lineup shown in Figure 1. The MAX2037 VGA has approximately $22\text{nV}/\sqrt{\text{Hz}}$ of output-referred noise. The MAX1437 12-bit, 50Msps ADC used to digitize the VGA's output has a $31.7\text{nV}/\sqrt{\text{Hz}}$ noise floor, given that the ADC's maximum input voltage is $1.4\text{V}_{\text{P-P}}$ and its specified SNR is 70dB. If the passive anti-alias filter between the VGA and ADC in this example has 0dB attenuation in the passband, then the 70dB SNR of the ADC would effectively be reduced by 1.7dB to 68.3dB as a result of the VGA's contributed output-referred noise. In practice, however, most anti-alias filters used in this application have some passband attenuation.

For stability reasons, many VGAs require some form of real output impedance driving the filter. These impedances must be large enough so the capacitor values in the filter are not unrealistically small. Such constraints usually result in a practical anti-alias filter with between 3dB to 6dB of attenuation in the passband. Attenuation in the anti-alias filter passband further reduces the output-referred noise seen at the input of the ADC and improves dynamic range. With 6dB of passband attenuation, there is only a 0.49dB reduction in the ADC's SNR due to the MAX2037's output-referred noise.

It is easy to see that VGAs with significantly more output-referred noise than the MAX2037 can be problematic. For example, VGAs with just $40\text{nV}/\sqrt{\text{Hz}}$ of output-referred noise, which is nearly twice the level of the MAX2037, result in a 1.5dB reduction in the ADC's SNR when using a 6dB attenuation anti-alias filter. This is a significant reduction, especially in difficult-to-image pulsed Doppler applications. It is important to note that the reduction in receiver gain caused by attenuation in the anti-alias filter can have significant negative effects on receiver noise figure, as we shall examine in more detail in the next section of this article.

The MAX2037 provides approximately half of the output-referred noise of competitive devices. It also has a significantly higher maximum gain to optimize dynamic range and preserve receiver noise figure when used with 12-bit ADCs and realistic passive anti-alias filters. **Figure 2** shows a plot of the MAX2037 output-referred noise as a function of gain.

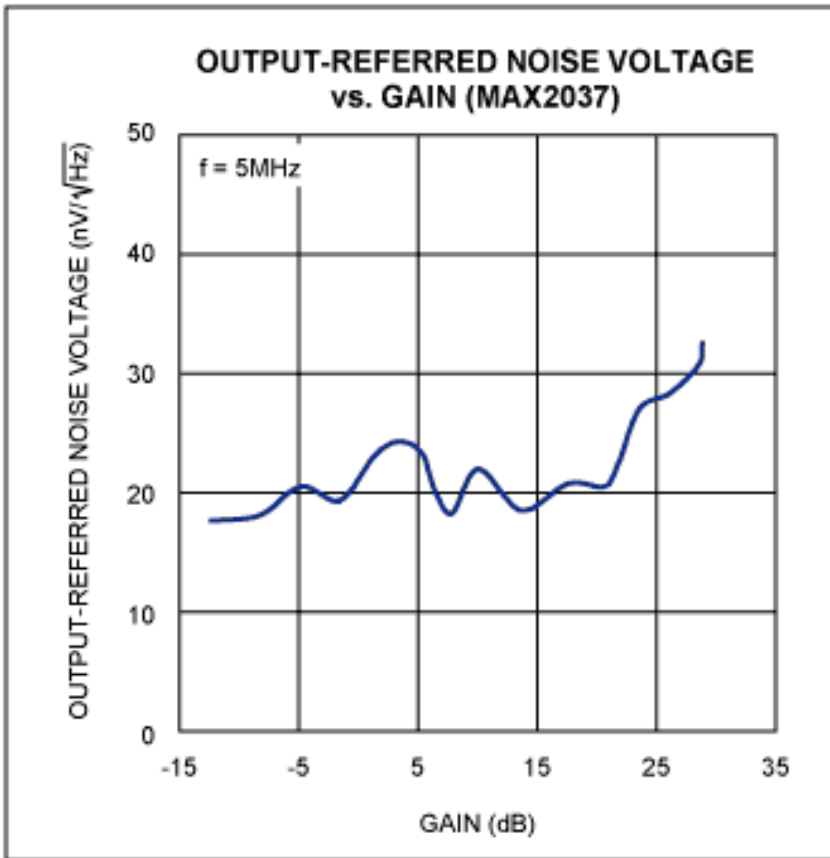

Figure 2. The MAX2037 features half the noise of competitive devices, while providing much higher gain.

Effect of VGA Maximum Gain on Receiver Noise Figure (High-TGC Gain Condition)

At high-TGC levels, where the receiver is optimized for small-signal sensitivity, the VGA's combined output-referred noise and the ADC's noise floor should be much less than the amplified transducer noise floor seen at the ADC's input.

The **Figure 3** simplified, ultrasound-receiver block diagram shows how receiver gain before the ADC affects noise-figure performance. The receiver lineup assumes the MAX2034 quad LNA with 19dB of gain, the MAX2037 VGA with a maximum gain of 29.5dB, and the MAX1437 octal 12-bit ADC. It also assumes an anti-alias filter with 6dB of attenuation in the passband. The assumed transducer impedance is 200Ω, which yields a thermal noise floor of $V_N = \sqrt{4 \times K \times T \times R \times \Delta F}$ or $1.8\text{nV}/\sqrt{\text{Hz}}$. The thermal noise floor at the LNA input, assuming an LNA Z_{IN} of 200Ω, is half of this value ($0.9\text{nV}/\sqrt{\text{Hz}}$). The full receiver lineup noise figure in this case is approximately 2.3dB when using typical noise specifications for the LNA, VGA, and ADC. The noise floor of the MAX1437 is $31.7\text{nV}/\sqrt{\text{Hz}}$. At maximum TGC levels, the gain of this lineup before the ADC, including the anti-alias filter, is 42.5dB. The ADC noise referred to the receiver input in this example is only $0.237\text{nV}/\sqrt{\text{Hz}}$ and, as a result, the ADC contributes only 0.18dB to the total receiver 2.3dB noise figure.

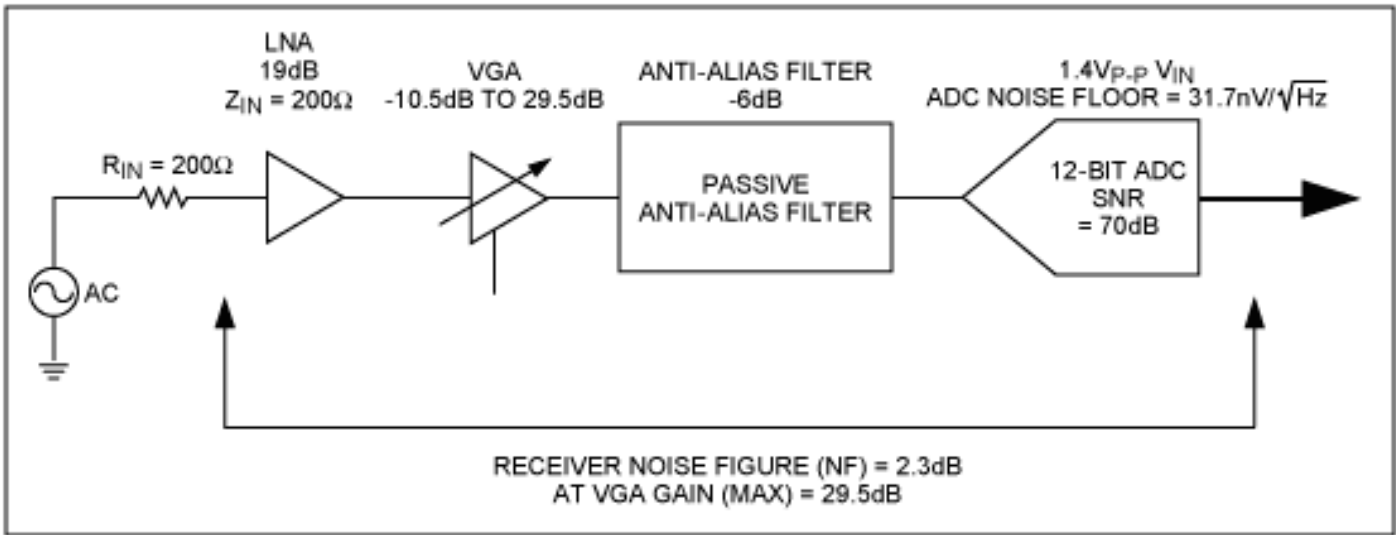

Figure 3. Gain before the ADC affects noise-figure performance in this simplified ultrasound-receiver block diagram.

What happens if the VGA has less maximum gain or the ADC's noise floor is higher? **Figure 4** shows the effect that VGA gain has on the small-signal noise figure of the typical ultrasound receiver shown in Figure 3. We plotted the noise figure for two different ADC noise floors, assuming that a MAX2034 low-noise ultrasound LNA with 19dB of gain and an anti-alias filter with 6dB of attenuation are in the receiver lineup. The top curve in the graph represents the MAX1437 with 1.4V_{p-p} maximum input voltage, SNR of 70dB, and a noise floor of approximately 31.7nV/√Hz. The other curve represents an ADC with 2V_{p-p} inputs, SNR of 70dB, and a resulting noise floor of approximately 45.2nV/√Hz. The graph clearly shows the effect of receiver noise figure on these two different ADCs. It also illustrates how the high 29.5dB maximum gain of the MAX2037 results in improved receiver noise figure. VGAs with less maximum gain result in higher overall receiver noise figure at maximum TGC levels and reduced small-signal Doppler sensitivity. A significant improvement in noise figure can be achieved by proper use of low-noise-floor ADCs, like the MAX1437, and high maximum gain VGAs, like the MAX2037.

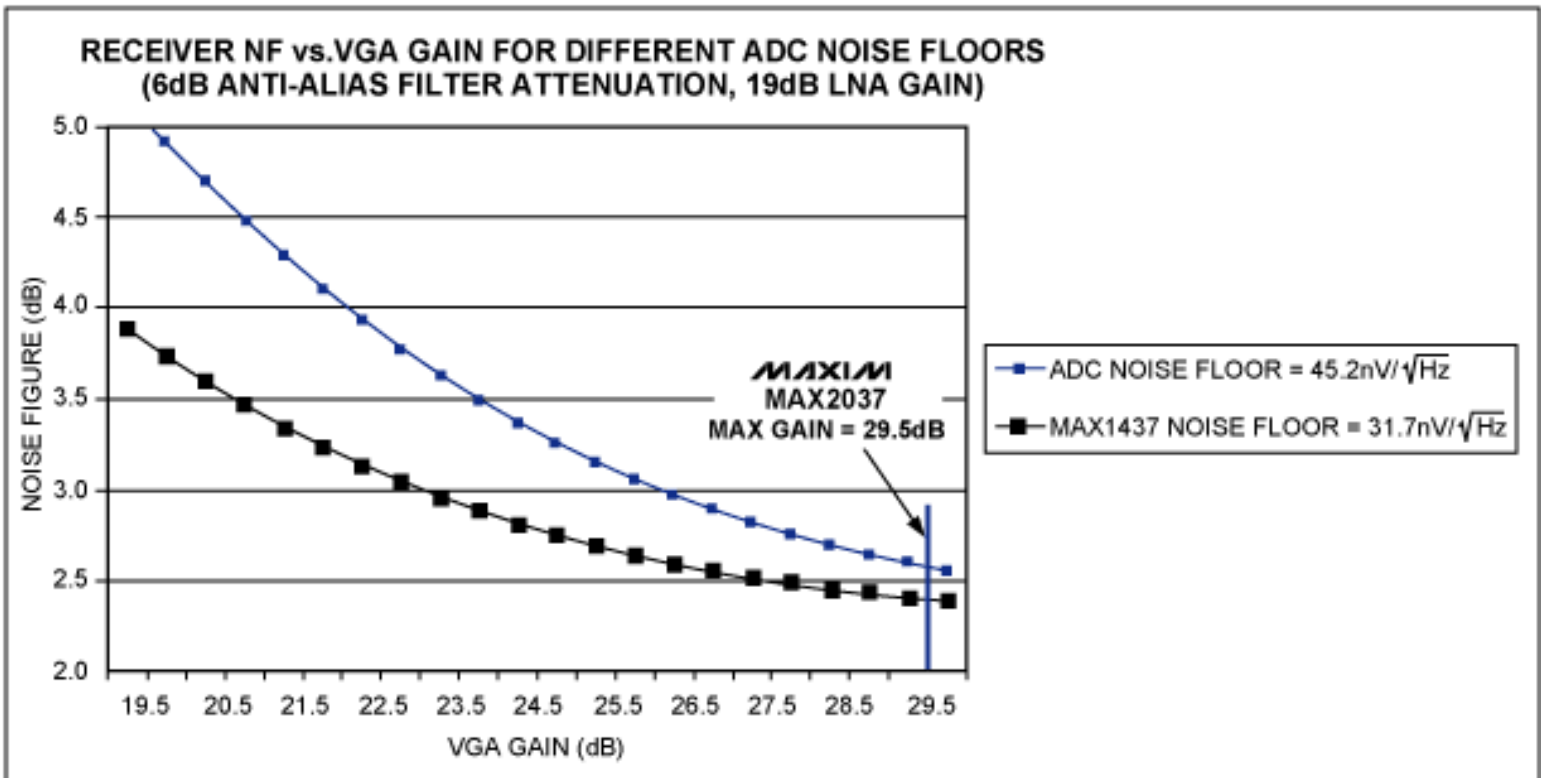

Figure 4. Receiver noise figure vs. VGA gain is shown for the Figure 3 ultrasound receiver.

Conclusion

Proper attention to the affect of VGA output-referred noise, maximum VGA gain, anti-alias filter attenuation, and ADC

noise on receiver dynamic range and noise figure is important and needs to be considered for optimal ultrasound-receiver sensitivity. The MAX2037 VGA optimizes and properly balances output-referred noise and maximum gain to ensure compatibility with 12-bit ADCs like the MAX1437 in order to achieve the best possible ultrasound-receiver performance.

Appendix A—Phased-Array Ultrasound System Basics

High-Level, Phased-Array Ultrasound System Block Diagram

Figure 5 shows a block diagram of a typical phased-array medical ultrasound imaging system. Systems using a phased-array approach like this require anywhere from 64 to 256 receive channels and a comparable number of transmit channels. In the Figure 5 block diagram, a single transmit-and-receive channel is shown for simplicity.

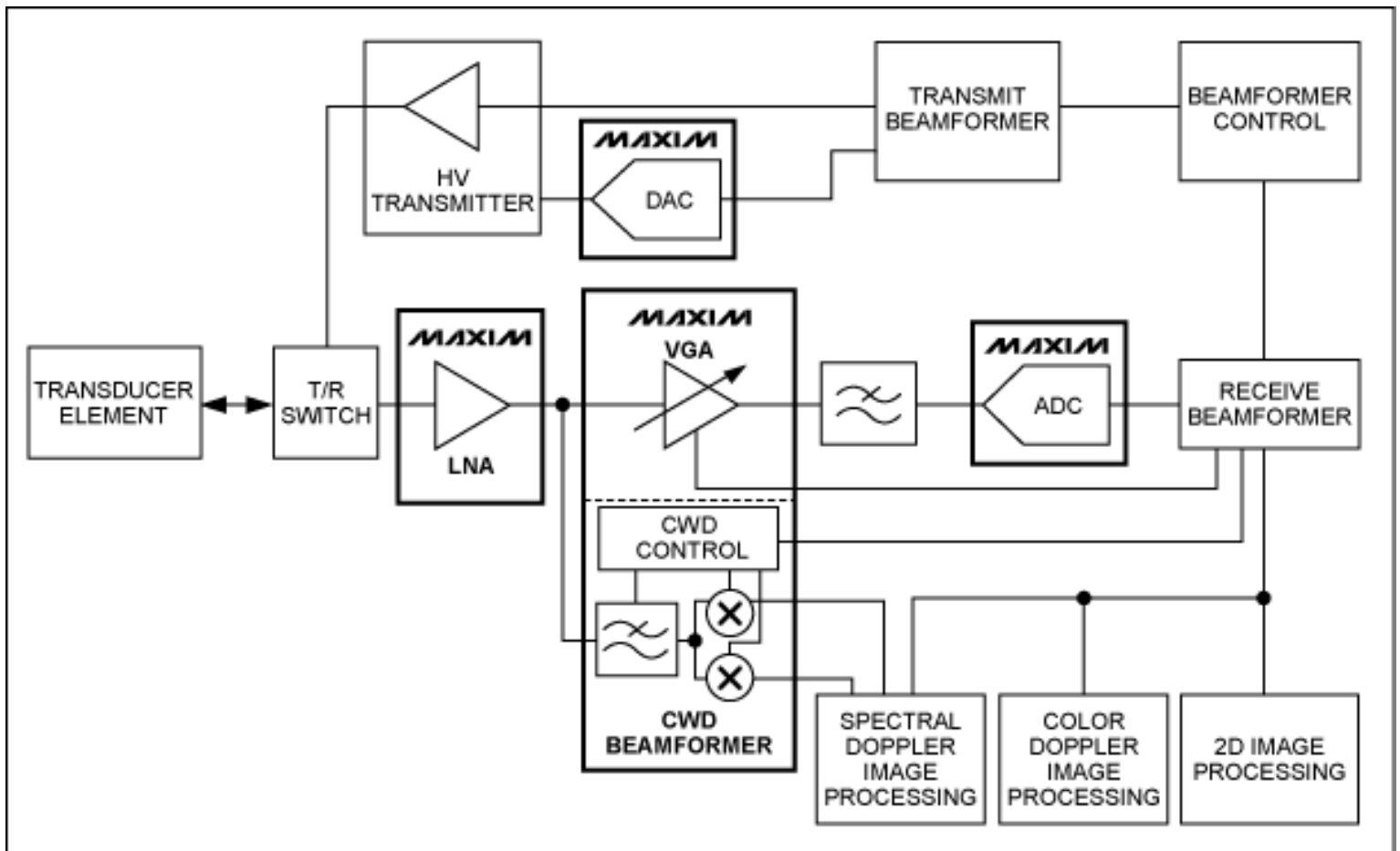

Figure 5. A single transmit-and-receive channel is shown for a typical phased-array medical ultrasound imaging system.

Ultrasound Transmit Basics

To produce an ultrasound image, a phased-array ultrasound system must produce N (where N = number of transmit channels) properly delayed, high-voltage transmit pulses. These pulses are used to excite the individual elements of a transducer array to produce a focused acoustic transmission (**Figure 6**).

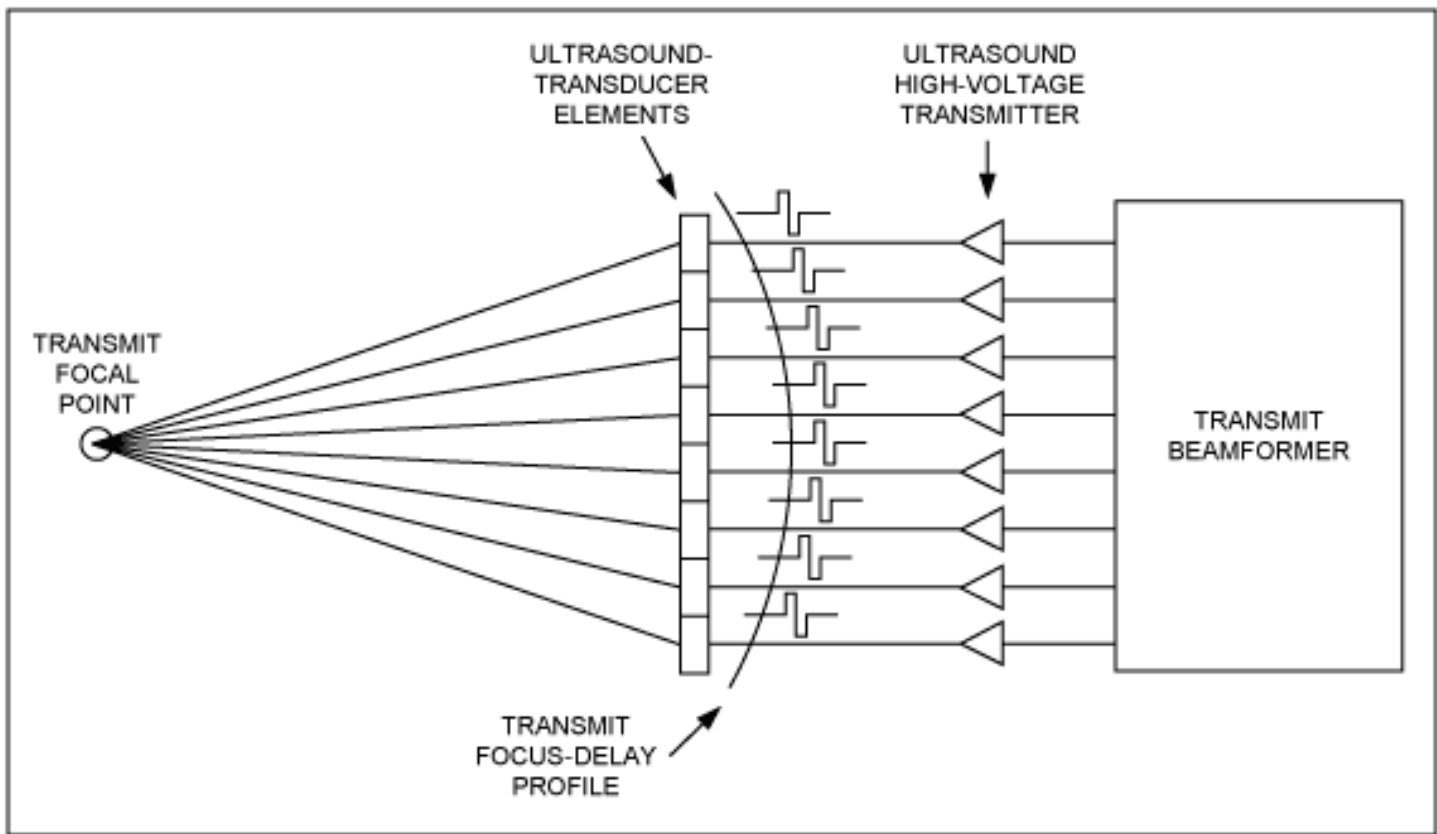

Figure 6. A focused acoustic transmission is produced by properly delayed, high-voltage transmit pulses.

Ultrasound Receiver Basics

Acoustic energy reflected from acoustic impedance discontinuities in the body are received by the transducer and routed to separate receive channels in the system. These receive channels amplify and then digitize the signals from each transducer element, as shown in **Figure 7**. Using a calculated delay profile, the digitized signals are delayed and summed in the ultrasound system's digital beamformer in order to generate a focused, receive beamformed signal. The resulting digital signal is used to generate 2D and PW/color-flow Doppler information.

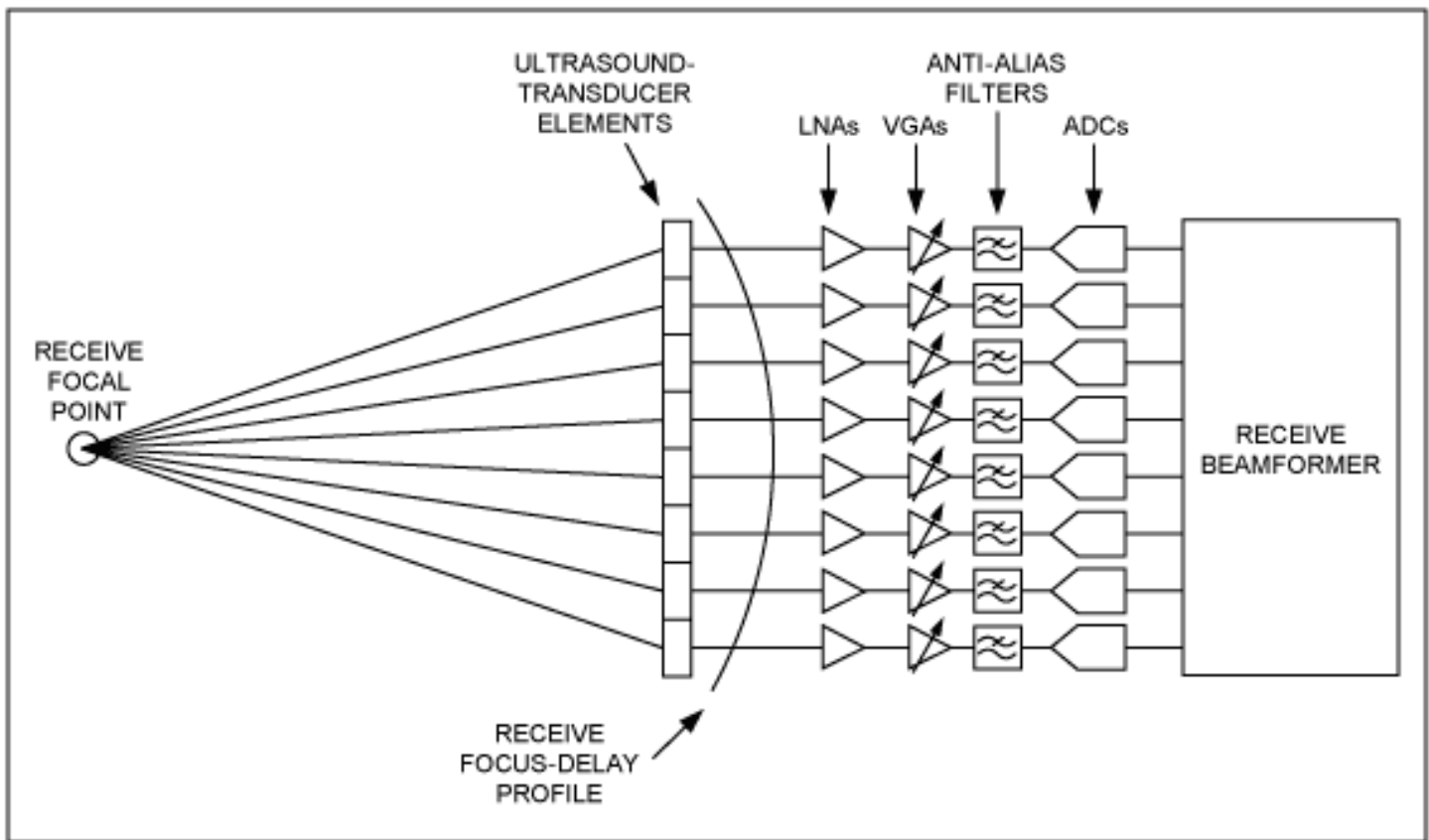

Figure 7. Signals from each transducer element are amplified and digitized by receive channels in the ultrasound-receiver system.

Application Note 4038: www.maxim-ic.com/an4038

More Information

For technical questions and support: www.maxim-ic.com/support

For samples: www.maxim-ic.com/samples

Other questions and comments: www.maxim-ic.com/contact

Keep Me Informed

Preview new application notes in your areas of interest as soon as they are published. Subscribe to [EE-Mail - Application Notes](#) for weekly updates.

Related Parts

MAX1437: [QuickView](#) -- [Full \(PDF\) Data Sheet](#)

MAX2034: [QuickView](#) -- [Full \(PDF\) Data Sheet](#) -- [Free Samples](#)

MAX2037: [QuickView](#) -- [Full \(PDF\) Data Sheet](#)

AN4038, AN 4038, APP4038, Appnote4038, Appnote 4038

Copyright © by Maxim Integrated Products

Additional legal notices: www.maxim-ic.com/legal