

APPLICATION NOTE 3989

Add Control, Memory, Security, and Mixed-Signal Functions with a Single Contact

Abstract: This application note provides a high-level overview of the 1-Wire® interface. It discusses power and data delivery along with data-bit-level communication, device selection, and the unalterable, unique ID in each device. As its name implies, the single-contact 1-Wire interface is an unmatched solution that provides key functions to systems where interconnect must be minimized.

Overview

The Dallas Semiconductor 1-Wire bus is a simple signaling scheme that performs half-duplex bidirectional communications between a host/master controller and one or more slaves sharing a common data line (**Figure 1**). Both power and data communication for slave devices are transmitted over this single 1-Wire line. For power delivery, slaves capture charge on an internal capacitor when the line is in a high state and then use this charge for device operation when the line is low during data transmission. A typical 1-Wire master consists of an open-drain I/O port pin with a resistor pullup to a 3V to 5V supply. More sophisticated masters, including dedicated line-driver solutions, are available from Dallas Semiconductor. This clever communication scheme also allows you to add memory, authentication, and mixed-signal functions at any time, easily and efficiently.

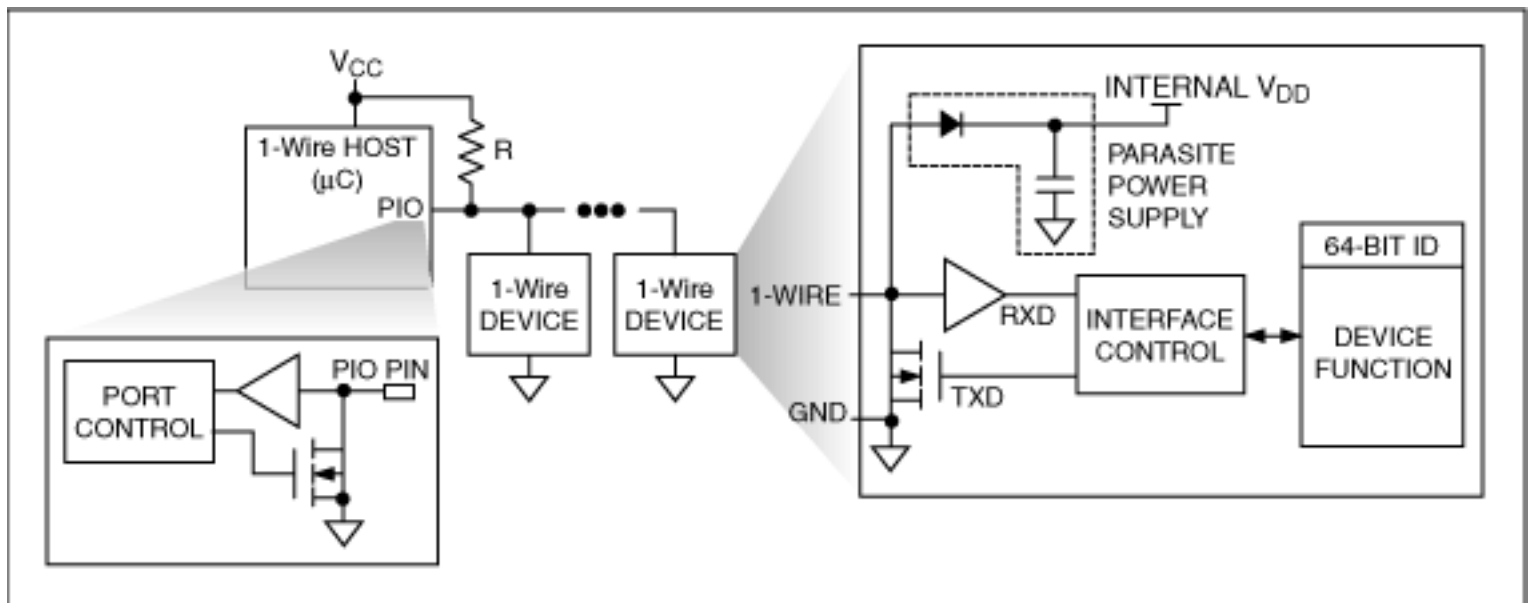

Figure 1. In a 1-Wire master/slave configuration, all devices share a common data line.

64-Bit Serial Numbers

There is an important, fundamental feature in every 1-Wire system: each slave device has a unique, unalterable (ROM), 64-bit, factory-lasered serial number (ID) that will never be repeated in another device. Besides providing a unique electronic ID to the end product, this 64-bit ID value allows the master device to select a slave device among the many that can be connected to the same bus wire. Part of the 64-bit ID is also an 8-bit family code that identifies the device type and functionality supported.

Data-Bit-Level Communication

The bus master initiates and controls all 1-Wire communication. As illustrated in **Figure 2**, the 1-Wire communication waveform is similar to pulse-width modulation, because data is transmitted by wide (logic 0) and narrow (logic 1) pulse widths during data-bit time periods or time slots. A communication sequence starts when the bus master drives a defined length "Reset" pulse that synchronizes the entire bus. Every slave responds to the Reset pulse with a logic-low "Presence" pulse. To write data, the master first initiates a time slot by driving the 1-Wire line low, and then either holds the line low (wide pulse) to transmit a logic 0 or releases the line (short pulse) to allow the bus to return to the logic 1 state. To read data, the master again initiates a time slot by driving the line with a narrow low pulse. A slave can then either return a logic 0 by turning on its open-drain output and holding the line low to extend the pulse, or a logic 1 by leaving its open-drain output off to allow the line to recover. Most 1-Wire devices support two data rates: Standard speed of about 15kbps, and Overdrive speed of about 111kbps. The protocol is self-clocking and tolerates long inter-bit delays, which ensures smooth operation in interrupted software environments.

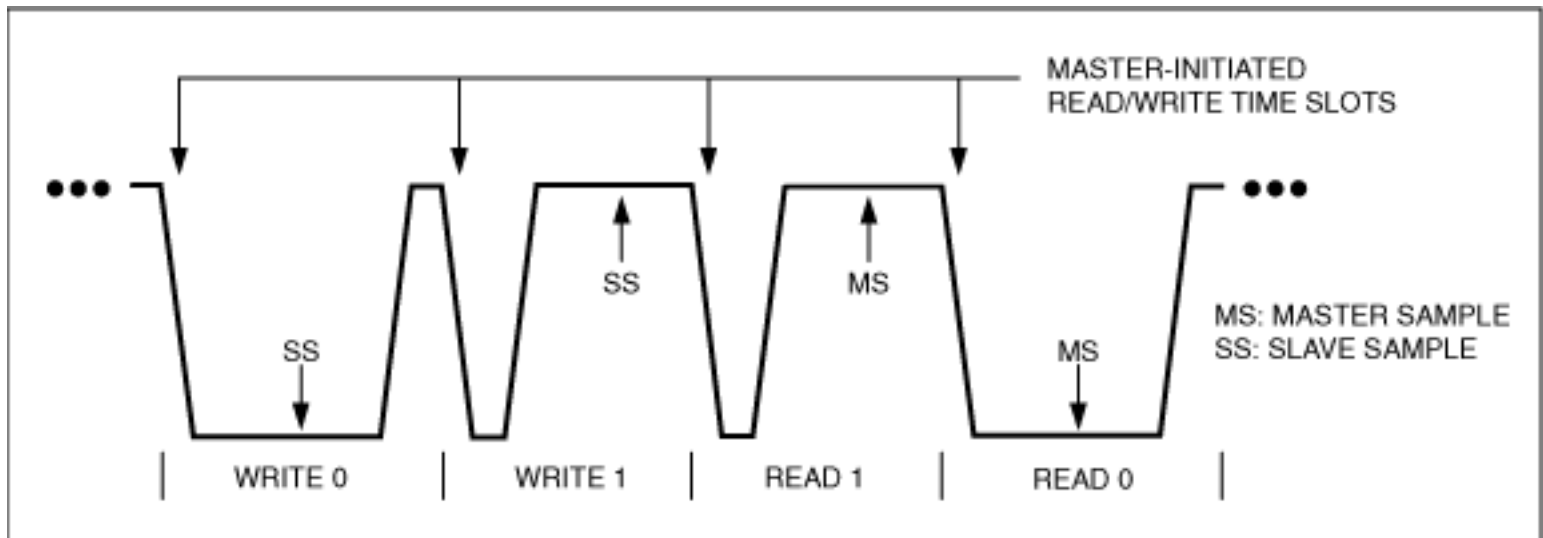

Figure 2. This waveform example shows master-initiated write/read of data bits with slave and master sampling points.

Device Selection

The first action in a 1-Wire communication is selecting a slave device for subsequent communications. In a single slave-device environment, the selection sequence is minimal. In a multidevice environment, however, slave selection is done either by selecting all slaves or a specific slave targeted by its 64-bit ID. A binary search algorithm (described as ROM-level commands in 1-Wire data sheets) enables the bus master to "learn" and subsequently select the respective 64-bit ID of any slave device on the line. Once a specific slave is selected, the master issues device-specific commands and sends data to it, or reads data from it. Meanwhile, all the other slave devices ignore communications until the next reset pulse is issued.

Summary

Layered on these 1-Wire fundamentals are a variety of memory, digital, analog, and mixed-signal functions. This variety results in a product portfolio optimized for applications where the single-contact 1-Wire interface can solve an interconnect-constrained problem and/or add value with unique product-line features. The 1-Wire products are available in standard IC packaging and the Company's rugged, stainless steel iButton package. Products, packaging, and extensive software support are detailed at [1-Wire Devices](http://www.maxim-ic.com/1-Wire%20Devices).

More Information

For technical questions and support: <http://www.maxim-ic.com/support>

For samples: <http://www.maxim-ic.com/samples>

Other questions and comments: <http://www.maxim-ic.com/contact>

Related Parts

DS2401: [QuickView](#) -- [Full \(PDF\) Data Sheet](#) -- [Free Samples](#)
DS2405: [QuickView](#) -- [Full \(PDF\) Data Sheet](#) -- [Free Samples](#)
DS2406: [QuickView](#) -- [Full \(PDF\) Data Sheet](#) -- [Free Samples](#)
DS2408: [QuickView](#) -- [Full \(PDF\) Data Sheet](#) -- [Free Samples](#)
DS2411: [QuickView](#) -- [Full \(PDF\) Data Sheet](#) -- [Free Samples](#)
DS2413: [QuickView](#) -- [Full \(PDF\) Data Sheet](#) -- [Free Samples](#)
DS2417: [QuickView](#) -- [Full \(PDF\) Data Sheet](#) -- [Free Samples](#)
DS2431: [QuickView](#) -- [Full \(PDF\) Data Sheet](#) -- [Free Samples](#)
DS2432: [QuickView](#) -- [Abridged Data Sheet](#)
DS2433: [QuickView](#) -- [Full \(PDF\) Data Sheet](#) -- [Free Samples](#)
DS2450: [QuickView](#) -- [Full \(PDF\) Data Sheet](#) -- [Free Samples](#)
DS2480B: [QuickView](#) -- [Full \(PDF\) Data Sheet](#) -- [Free Samples](#)
DS2482-100: [QuickView](#) -- [Full \(PDF\) Data Sheet](#) -- [Free Samples](#)
DS2502: [QuickView](#) -- [Full \(PDF\) Data Sheet](#) -- [Free Samples](#)
DS2505: [QuickView](#) -- [Full \(PDF\) Data Sheet](#) -- [Free Samples](#)
DS28E01-100: [QuickView](#) -- [Abridged Data Sheet](#)
DS28E04-100: [QuickView](#) -- [Full \(PDF\) Data Sheet](#) -- [Free Samples](#)
DS28EA00: [QuickView](#) -- [Full \(PDF\) Data Sheet](#) -- [Free Samples](#)

AN3989, AN 3989, APP3989, Appnote3989, Appnote 3989

Copyright © by Maxim Integrated Products

Additional legal notices: <http://www.maxim-ic.com/legal>