



APPLICATION NOTE 3580

Redundant-Transceiver RS-232 Link Has $\pm 40V$ Overvoltage Protection

Abstract: Parallel RS-232 transceivers can offer extra reliability in safety-critical applications. But such redundant transceivers put extra load on the data bus. This application note shows how the problem can be overcome by buffering the transceivers with a line protector. Overvoltage protection is increased in the process.

The RS-232 standard is intended primarily for point-to-point communications between one transmitter and one receiver, but in some circumstances it may be necessary to connect more than one transceiver to the link. For example, redundant transceivers provide extra reliability in safety-critical applications.

Multiple transceivers load the data bus, however. For instance, if two transmitters—one from each of two separate MAX211 transceivers—are connected in parallel (to the same link), the unused device (whether shut down or with power removed) will adversely affect the active device by loading the data bus. Figure 1's circuit avoids this problem while increasing the overvoltage protection from that of the transceivers to that of the line protectors ($\pm 40V$).

Each of the parallel RS-232 transceivers (IC1 and IC2) is buffered by a 2-terminal, multichannel line protector (IC3 and IC4). The line protectors normally exhibit about 60Ω im between each input-output pair, but that resistance goes to a high impedance if power is removed or if either terminal rises to within 1.5V of a supply rail. The line protectors are powered by charge pumps internal to the transceivers, so either will lose power if its associated transceiver loses power or is shut down. Thus, an inactive transceiver is automatically disconnected from the line.

To ensure that the line protectors have sufficient power-supply headroom to accommodate the transceivers' $\pm 5V$ transmitter-output specification, external diode-capacitor charge pumps boost the transceivers' V- outputs to a more negative level. The $100k\Omega$ resistors discharge this negative rail when the transceiver is shut down or turned off. The system's various states are summarized in **Table 1**.

Table 1. System States

Tx CONDITION	Tx (V+)	Tx (V-)	LINEPROTECTOR (V-)
Active	$\sim 2VCC$	$\sim -2VCC$	$\sim -3VCC$
Shutdown	VCC	Ground	Ground
Power Off	Ground	Ground	Ground

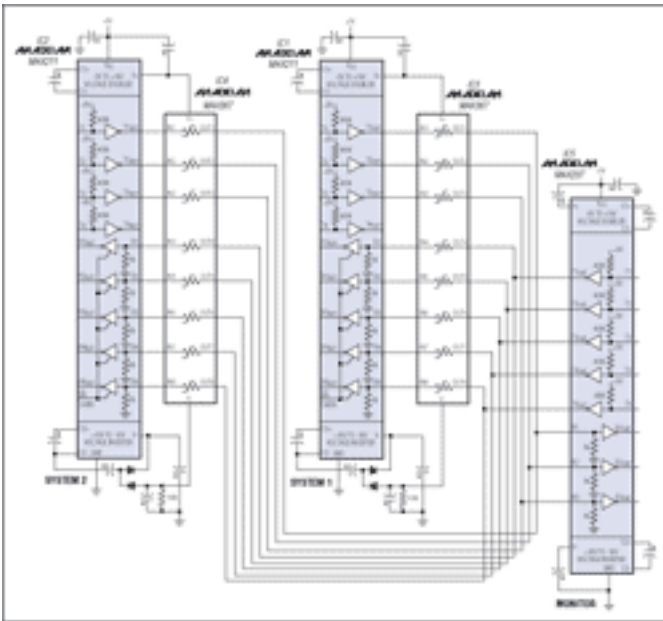

[For Larger Image](#)

Figure 1. Line protectors IC3 and IC4 prevent either of the two parallel transceivers (IC1 and IC2) from loading the data bus while they are inactive (shut down or turned off).

A similar version of this article appeared in the December 1996 issue of *Electronic Product Design (UK)* magazine

Application Note 3580: www.maxim-ic.com/an3580

More Information

For technical support: www.maxim-ic.com/support

For samples: www.maxim-ic.com/samples

Other questions and comments: www.maxim-ic.com/contact

Automatic Updates

Would you like to be automatically notified when new application notes are published in your areas of interest?

[Sign up for EE-Mail™.](#)

Related Parts

MAX211: [QuickView](#) -- [Full \(PDF\) Data Sheet](#) -- [Free Samples](#)

MAX232: [QuickView](#) -- [Full \(PDF\) Data Sheet](#) -- [Free Samples](#)

AN3580, AN 3580, APP3580, Appnote3580, Appnote 3580

Copyright © by Maxim Integrated Products

Additional legal notices: www.maxim-ic.com/legal