



APPLICATION NOTE 3513

## Design Challenges for Backlighting LCD TVs

*Abstract: LCDs (liquid crystal displays) are electronically controlled light valves. LCD TVs (liquid crystal display televisions) use a white "backlight," typically cold-cathode fluorescent lamps (CCFLs), to illuminate the color screen. Other technologies, such as light-emitting diodes (LEDs), have been considered, but high cost has limited their adoption.*

*This article describes the design challenges of driving and controlling multiple CCFLs for backlighting large LCD panels like those in LCD TVs.*

### Design Challenges

Because LCD TVs are consumer items, the overriding design factor is cost—yet a certain minimum level of performance must be maintained. The CCFL inverter must drive the lamps in a manner that will not dramatically shorten the lamp life. Also, because high voltages are generated in driving the lamps, safety must be considered. This article focuses on three key design challenges in driving multiple CCFLs in LCD-TV applications: picking the best drive architecture, driving multiple lamps, and tight control over the lamp- and burst- dimming frequencies.

### Picking the Best Drive Architecture

Creating the high-voltage AC waveform needed to drive CCFLs can be realized through a number of architectures including Royer (self-oscillating), half bridge, full bridge, and push-pull. **Table 1** details the advantages and disadvantages of these four architectures.

**Table 1. CCFL Drive Architecture Comparison**

Drive Architecture	Advantages	Disadvantages
Royer	<ul style="list-style-type: none"> <li>Least expensive</li> </ul>	<ul style="list-style-type: none"> <li>Cannot tightly control the lamp current or frequency</li> <li>Requires tight DC-supply regulation</li> <li>Requires a special transformer winding</li> <li>Requires a ballast capacitor</li> <li>Low efficiency</li> </ul>
Full Bridge	<ul style="list-style-type: none"> <li>Does not require a center-tapped transformer</li> <li>Works over a wide DC-supply range (greater than 3:1)</li> </ul>	<ul style="list-style-type: none"> <li>Requires four MOSFETs</li> <li>May require p-channel MOSFETs, which are higher cost and less efficient</li> </ul>
Half Bridge	<ul style="list-style-type: none"> <li>Requires only two MOSFETs</li> </ul>	<ul style="list-style-type: none"> <li>May require p-channel MOSFETs, which are higher cost and less efficient</li> <li>Requires a higher turns ratio transformer, which increases cost</li> </ul>
Push-Pull	<ul style="list-style-type: none"> <li>Requires only two n-channel MOSFETs, which are lower in cost and more highly efficient than p-channel MOSFETs</li> <li>Easily scales to higher DC supply voltages (up to 120V)</li> <li>Low transformer turns ratio</li> </ul>	<ul style="list-style-type: none"> <li>Lower efficiency when the DC supply goes beyond a 2:1 range</li> </ul>

## Royer Architecture

The best application for Royer architecture (**Figure 1**) is in designs where the lamp frequency and brightness do not need to be tightly controlled. Because Royer architecture is a self-oscillating design containing variations in component values, it is difficult to control the exact lamp frequency and lamp current, both of which directly affect lamp brightness. For these reasons, Royer architecture is almost never used in LCD-TV applications, although its implementation is the least expensive of the four architectures presented here.

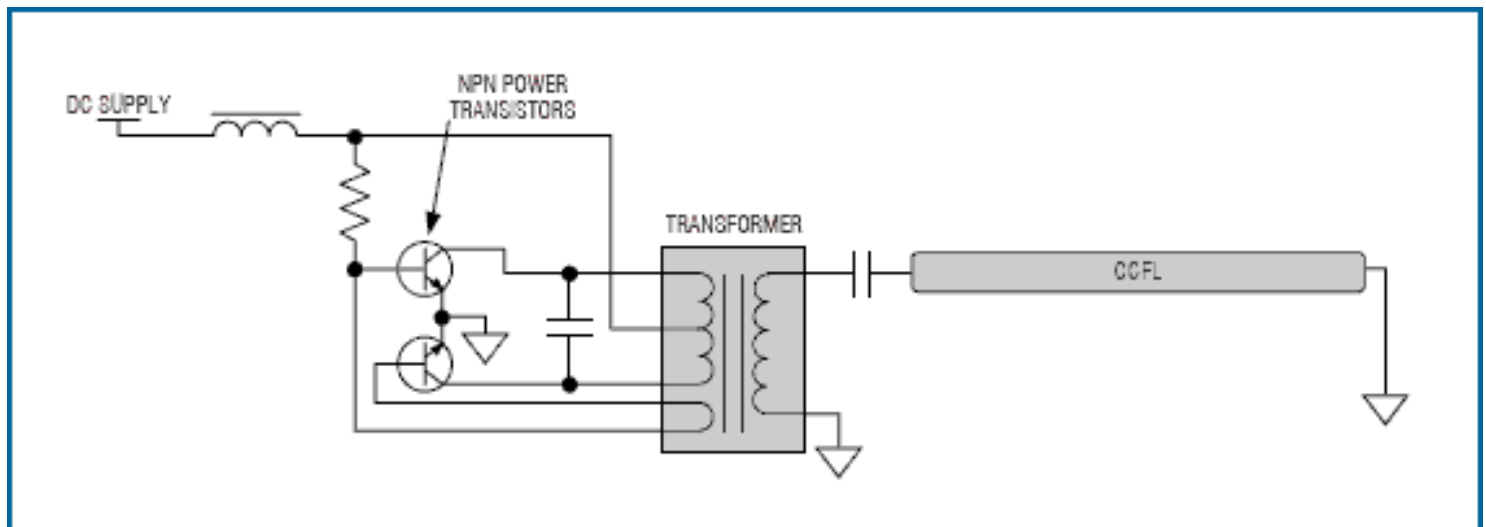

Figure 1. Royer drives are simple, but not very accurate.

## Full-Bridge Architecture

Full-bridge architecture is best suited for applications that require a very wide DC supply-voltage range (**Figure 2**). This is why almost all notebook PCs use a full-bridge approach. The inverter's DC supply is tied directly to the notebook main DC power source, which can vary from 7V (low battery) to 21V (AC charging). Some full-bridge implementations do require p-channel MOSFETs, which are more expensive than n-channel MOSFETs. Also, p-channel MOSFETs are less efficient due to their inherent higher on-resistance.

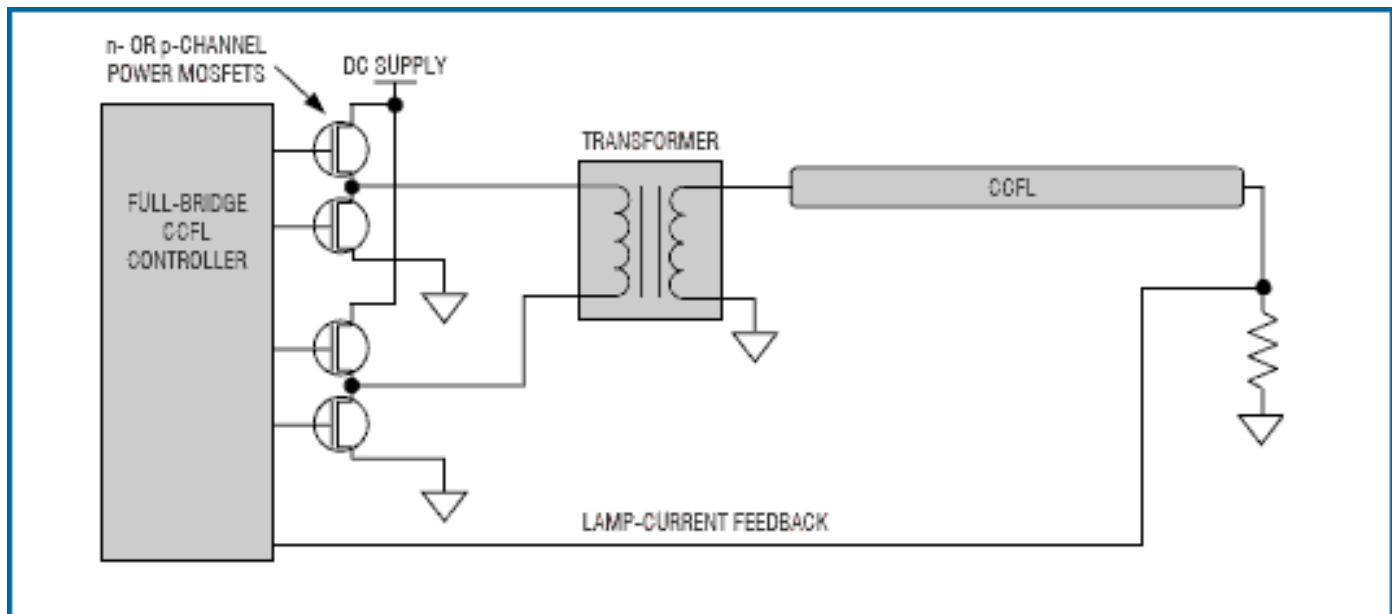

Figure 2. Full-bridge drives work well over a large DC-inverter supply range.

## Half-Bridge Architecture

The biggest advantage of the half-bridge architecture is that it requires two fewer MOSFETs per drive channel than full-bridge architecture (**Figure 3**). It does, however, require a transformer with a higher turns ratio, thus increasing the cost of the transformer. Also, like full-bridge architecture, half-bridge architecture may require p-channel MOSFETs.

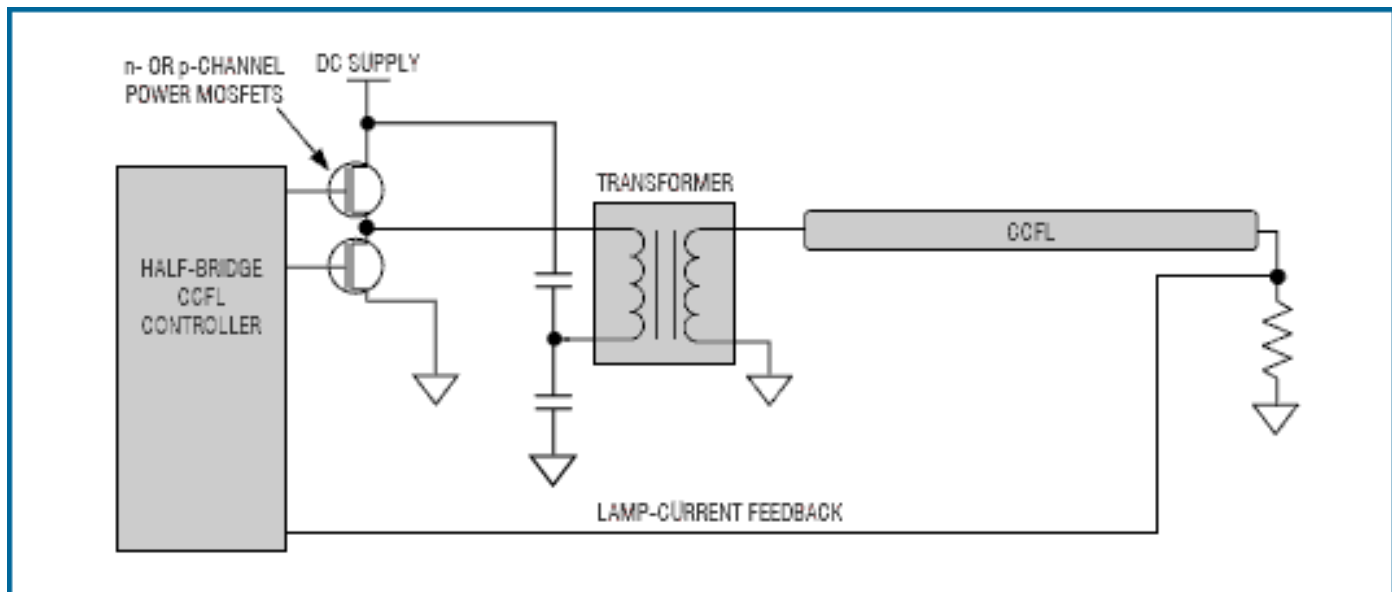

Figure 3. Half-bridge drives require two fewer MOSFETs than full-bridge drives.

## Push-Pull Architecture

The final architecture to consider is a push-pull drive, which has a number of advantages. This architecture only uses n-channel MOSFETs (**Figure 4**), the use of which reduces cost and raises the efficiency of the inverter. It easily scales to higher DC-inverter supply voltages. Using a higher DC-inverter supply voltage only requires selecting a MOSFET with the appropriate drain-source breakdown voltage. The same CCFL controller can be used regardless of the DC-inverter supply voltage. This is not the case for full- and half-bridge architectures using n-channel MOSFETs.

The biggest disadvantage of push-pull architecture is that the DC-inverter supply range should be less than 2:1. Otherwise, the system efficiency will drop due to the AC waveforms' high crest factor when the DC-inverter supply voltage is high. This makes the push-pull architecture inappropriate for notebook PCs, but ideal for LCD TVs in which the DC-inverter supply voltage is regulated to within  $\pm 20\%$ .

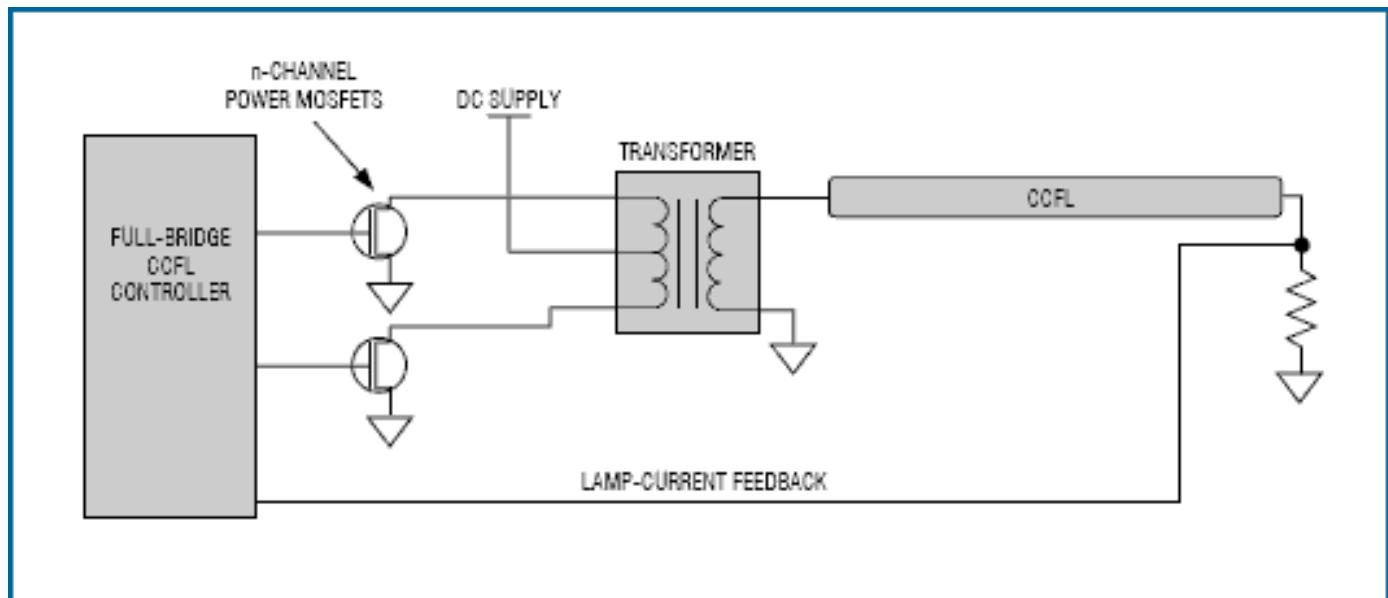

Figure 4. Push-pull drives are simple, yet provide accurate control.

## Driving Multiple Lamps

CCFLs have been used for a number of years in notebook PCs, digital cameras, navigation systems, and other equipment with smaller LCD screens. These types of equipment typically have only one CCFL, for which the traditional technique uses one CCFL controller. With the advent of large LCD panels where many CCFLs are needed, new approaches are necessary. One possible approach is to use a single-channel CCFL controller to operate multiple lamps (**Figure 5**). In this approach, the CCFL controller monitors the lamp current through only one of the lamps, and then drives all the lamps in parallel with approximately the same AC waveform. There are, however, several shortcomings with this approach.

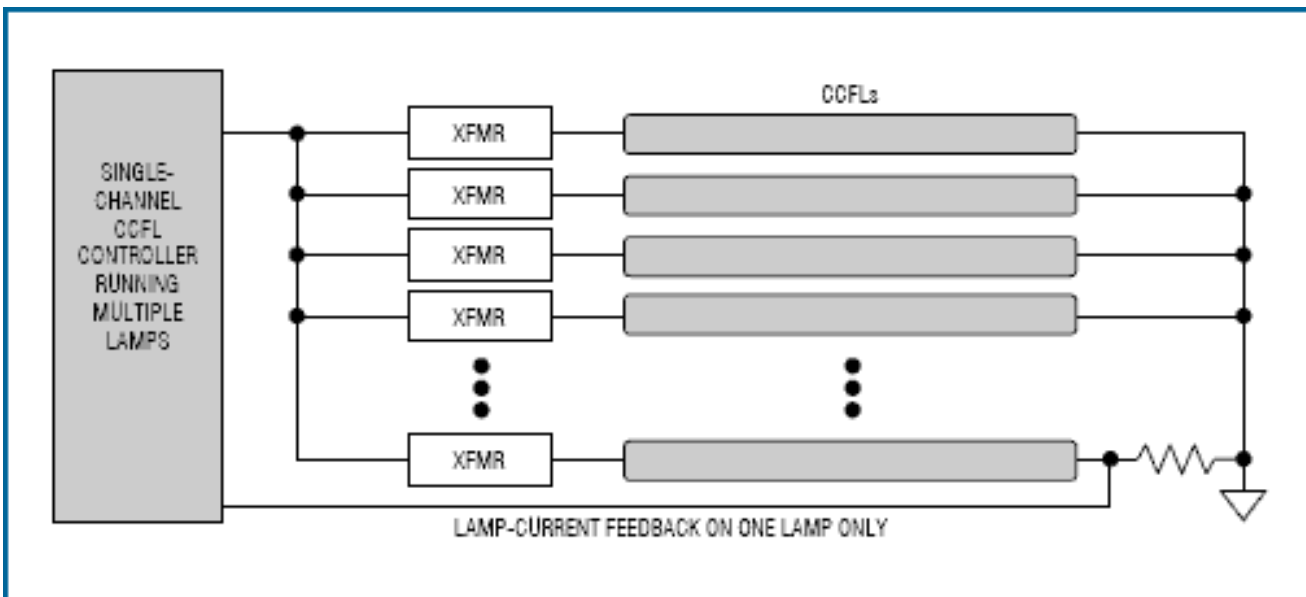

Figure 5. Controlling multiple lamps with a single-channel CCFL controller is not ideal due to the potential for uneven brightness, among other concerns.

The first problem is maintaining equal brightness across all the lamps so no bright or dull spots are apparent to the viewer. Driving all the lamps with the same waveform causes each lamp to have a different current driven through it, hence a different brightness. Also, using the same waveform can cause uneven brightness due to differences in the lamp impedances. Furthermore, the brightness of CCFL varies with temperature (Figure 6). Because heat rises, the lamps at the top of the panel (sidebar, Figure 12) will be hotter than the lamps at the bottom of the panel, again causing uneven brightness.

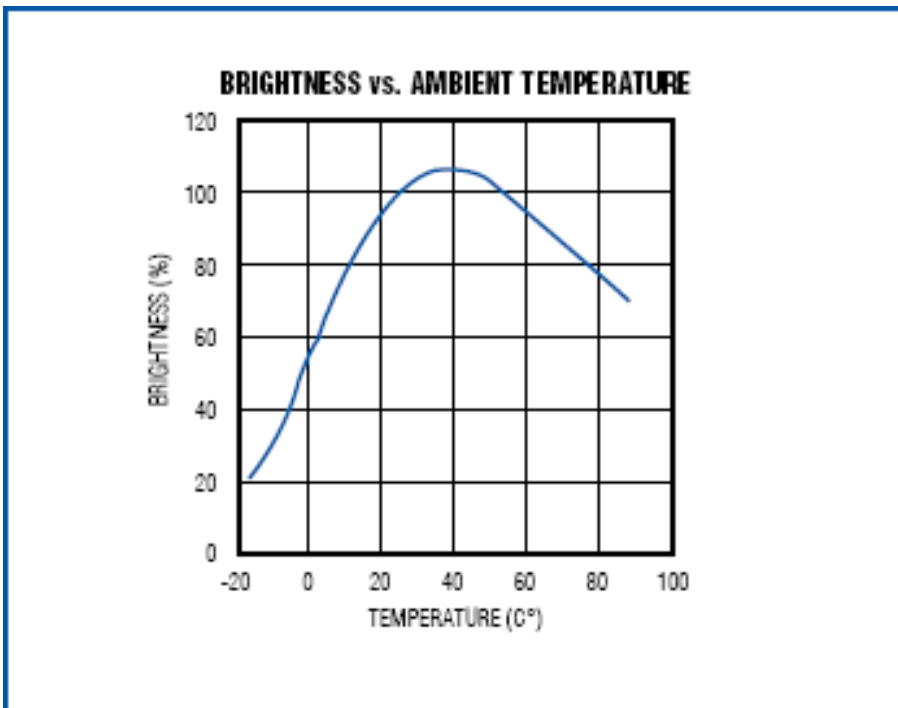

Figure 6. The brightness of CCFLs varies with ambient temperature.

The second disadvantage to using a single-channel CCFL controller to drive multiple lamps is that a single lamp failure (like lamp breakage) will cause all the lamps to turn off. A third disadvantage is that, because all the lamps are driven in parallel and turned on and off simultaneously, the DC inverter supply must be more heavily decoupled with bulk capacitance. This raises the cost of the inverter.

One way to solve these several problems is to use a separate CCFL controller for each lamp (Figure 7). The major disadvantage to this approach, however, is the extra cost due to additional CCFL controllers. The ideal solution for backlighting LCD panels is a multichannel CCFL controller that can drive and monitor each lamp independently (Figure 8). The multichannel CCFL controller thus resolves the issues of uneven brightness and single-lamp failure,

reduces the required decoupling, and is cost-effective.

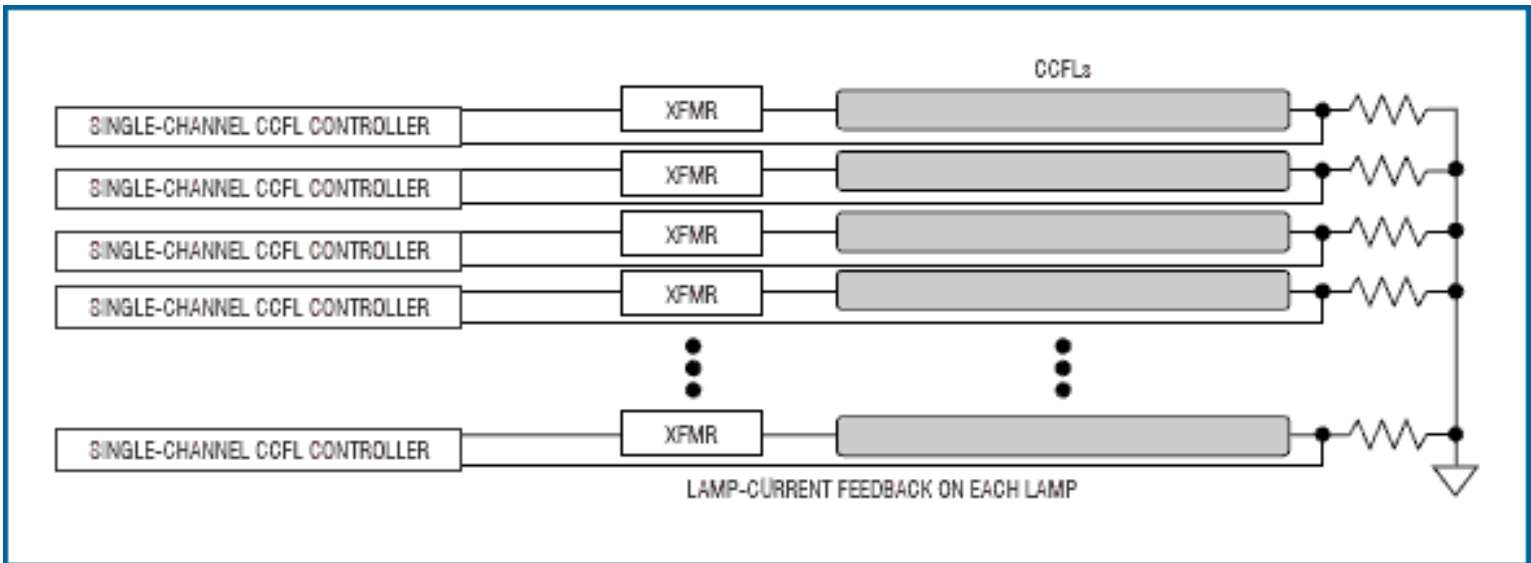

Figure 7. Using a single-channel controller for each CCFL is not cost effective.

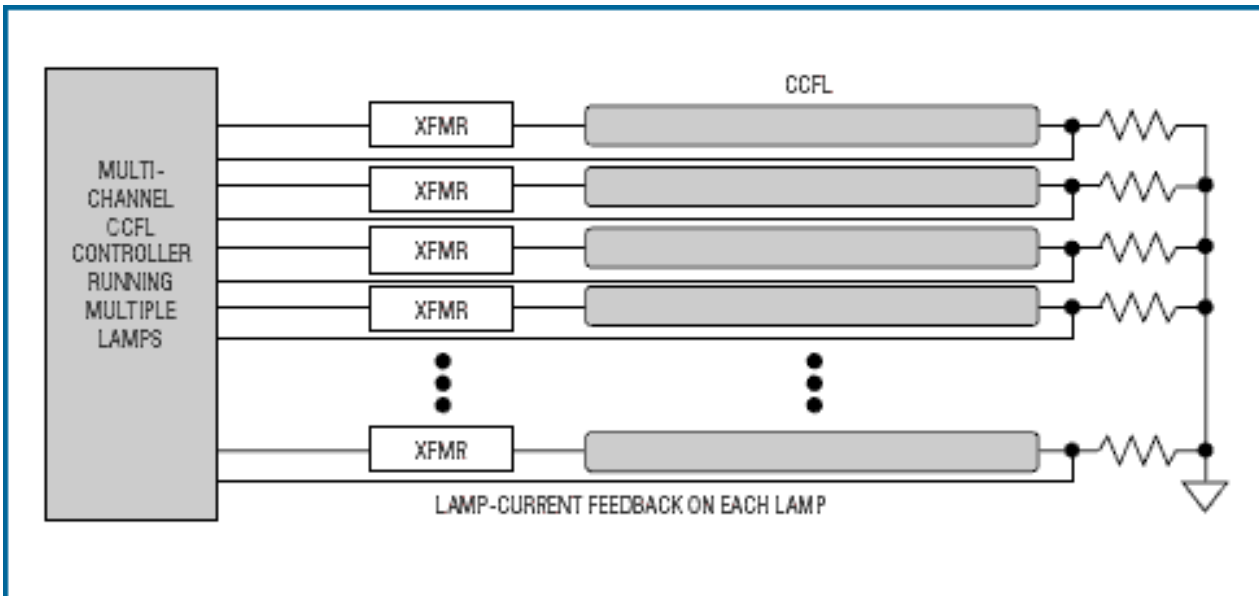

Figure 8. Controlling multiple lamps with a multichannel controller is the ideal approach.

## Tight Control over the Lamp and Burst-Dimming Frequencies

Because LCD-TV displays are dynamic and continually showing moving images, they have some additional requirements that do not exist in static display applications, like computer monitors and notebook PCs. The frequency at which a CCFL is driven can interfere with the image displayed on the LCD screen. Slow-moving lines or bars can be created if the lamp frequency is near a constant multiple of the video update rates. Eliminating these artifacts can be accomplished by tight control of the lamp frequency to within  $\pm 5\%$ .

The same tight control is required for the burst-dimming frequency, used to adjust the brightness of the lamps. Typically a pulse-width modulated (PWM) signal in the 30Hz to 200Hz range turns the lamps off for a short period of time, though not long enough for them to lose ionization. If the burst-dimming frequency is near a multiple of the vertical sync rate, rolling lines can be created. Again, control of the burst-dimming frequency within a  $\pm 5\%$  level eliminates this problem. Also, in some LCD-TV applications, it is necessary to synchronize the slow burst-dimming frequency of the CCFLs to the vertical sync rate to improve the image response of the LCD panel.

## A Solution for the LCD TV Backlighting Challenges (DS3984/DS3988)

The DS3984 (four channel) and the DS3988 (eight channel) CCFL controllers solve all the design challenges raised in this article. These devices can be configured to drive one lamp per channel (**Figure 9**), or multiple lamps per channel (**Figure 10**), which allows the user to adapt the design to meet their cost vs. performance target. Multiple DS3984/DS3988s can be easily cascaded to support as many lamps as necessary for backlighting LCD TV panels.

The DS3984/DS3988 use a push-pull drive, which allows the use of lower cost, higher efficiency n-channel MOSFETs. Also, the DC-inverter supply voltage can be easily scaled to a higher voltage. The individual lamp control and monitoring provides even lamp brightness, and reduces the overall component count in the inverter design. With individual lamp control, if a lamp fails, only the failing lamp is disabled. The other lamps continue to operate. Onboard lamp- and burst-dimming oscillators specified to a tight  $\pm 5\%$  level eliminate visual artifacts, and can be synchronized to external clock sources.

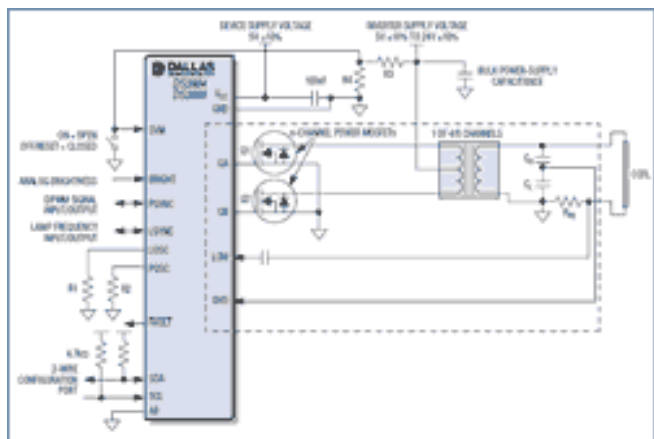

[For Larger Image](#)

Figure 9. The DS3984/DS3988 drive and monitor each lamp independently for even brightness in LCD TVs and PC monitors.

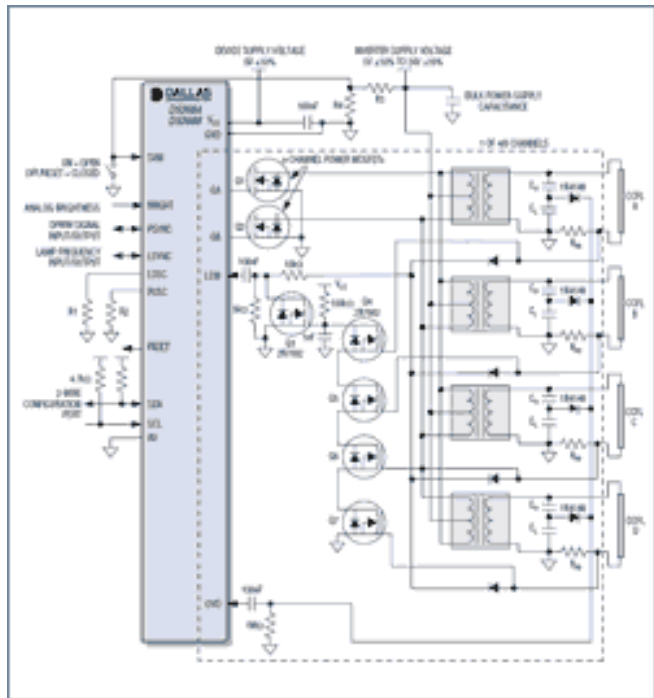

[For Larger Image](#)

Figure 10. The DS3984/DS3988 can also drive multiple lamps per channel.

## CCFLs

Cold-cathode fluorescent lamps (CCFLs) are long, sealed glass tubes of small diameter filled with inert gases

(Figure 11). When a high voltage is sent across the tube, the gases ionize, creating ultraviolet (UV) light. This, in turn, excites an inner coating of phosphor, creating visible light. CCFLs have many desirable features, including:

- Excellent white light source
- Low cost
- High efficiency (electrical power in to light out)
- Long life (>25kilohours)
- Stable and predictable operation
- Easily varied brightness
- Light weight

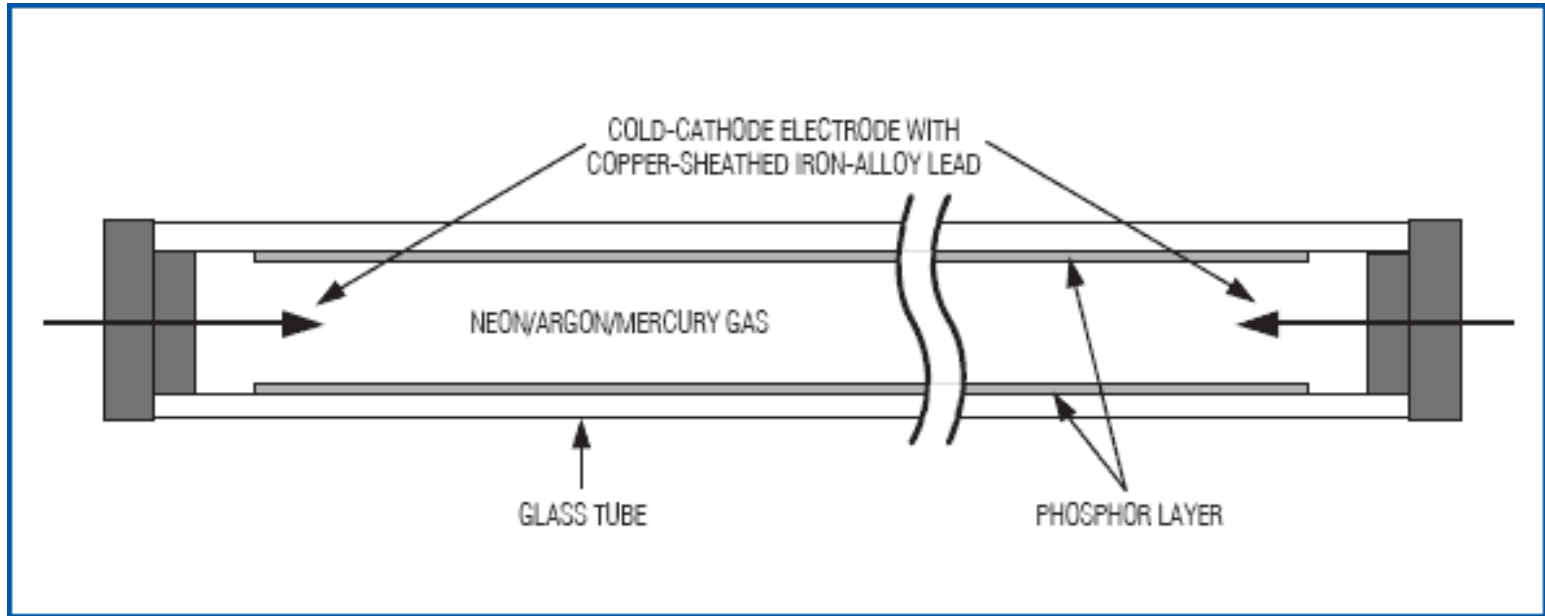

Figure 11. CCFLs are glass tubes filled with inert gasses.

CCFLs have some unique characteristics that must be accounted for in order to maximize their efficiency, life span, and usefulness. These characteristics, however, do cause design challenges. For example, to maximize the life of the lamps, CCFLs need to be driven with an AC waveform. Any DC component can cause some of the gasses to accumulate at one end of the tube and create an irreversible light gradient where one end of the tube is brighter than the other. Also, to maximize their efficiency (power in to light out), the lamps need to be driven with near-sinusoidal waveforms. To accomplish these tasks, CCFLs typically require a DC-to-AC inverter that transforms a DC-supply voltage to a 40kHz to 80kHz AC waveform, with an operating voltage of  $500V_{RMS}$  to  $1000V_{RMS}$ .

## Typical CCFL Arrangement in LCD TVs

Figure 12 shows how CCFLs are typically arranged in an LCD TV. The 12 lamps in this TV are equally spaced across the LCD backplane to provide the best possible light distribution. It is important that all the lamps operate at the same brightness level. Although there is a light diffuser placed between the CCFL lamps and the LCD panel to help evenly distribute the backlighting, uneven lamp brightness can still be visible and detract from the quality of the TV image. Depending on the size of the LCD panel, up to 30 or even 40 CCFL lamps may be required.



Figure 12. LCD TVs contain from 4 to 40 CCFLs.

---

Application Note 3513: [www.maxim-ic.com/an3513](http://www.maxim-ic.com/an3513)

#### More Information

For technical support: [www.maxim-ic.com/support](http://www.maxim-ic.com/support)

For samples: [www.maxim-ic.com/samples](http://www.maxim-ic.com/samples)

Other questions and comments: [www.maxim-ic.com/contact](http://www.maxim-ic.com/contact)

---

#### Automatic Updates

Would you like to be automatically notified when new application notes are published in your areas of interest? [Sign up for EE-Mail™](#).

---

#### Related Parts

DS3984: [QuickView](#) -- [Full \(PDF\) Data Sheet](#) -- [Free Samples](#)

DS3988: [QuickView](#) -- [Full \(PDF\) Data Sheet](#) -- [Free Samples](#)

AN3513, AN 3513, APP3513, Appnote3513, Appnote 3513

Copyright © by Maxim Integrated Products

Additional legal notices: [www.maxim-ic.com/legal](http://www.maxim-ic.com/legal)