



APPLICATION NOTE 3439

PIC'ing the MAX5591: Interfacing a PIC Microcontroller to the MAX5591 Fast-Settling DAC

Abstract: A tutorial is presented on interfacing a PIC18F442 microcontroller to the MAX5591 fast-settling DAC, with an example program.

MAX5591 Overview

The [MAX5591](#) is a 12-bit, fast-settling DAC featuring a 3-Wire SPI™ serial interface. The MAX5591 interface is capable of supporting SPI up to 20MHz, with a maximum settling time of 3μs. This application note contains descriptions of an application circuit and all the firmware required to interface the fastest line of PIC microcontrollers (the PIC18F core) to the MAX5591. The example assembly program was written specifically for the PIC18F442, using the free assembler provided in MPLAB® IDE version 6.10.0.0.

Hardware Overview

The application circuit utilizes the MAX5591EVKIT, which consists of the MAX5591, an ultra-high-precision voltage reference (MAX6126), two push-button switches, gain-setting resistors, and a proven PCB layout. The PIC18F442 is not present on the MAX5591EVKIT board, but it was added to the system here to complete the application schematic shown in **Figure 1**. The /CS\, SCLK, DIN and DOUT pads on the MAX5591EVKIT allow an easy connection for the SPI serial interface.

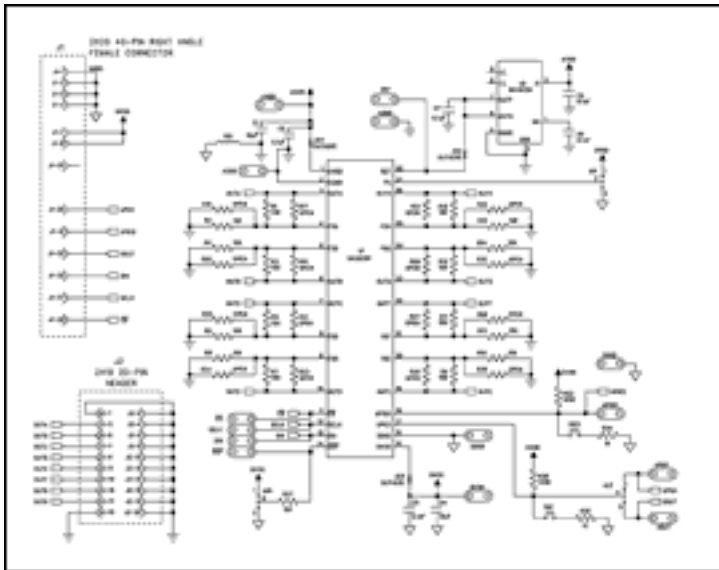

[For Larger Image](#)

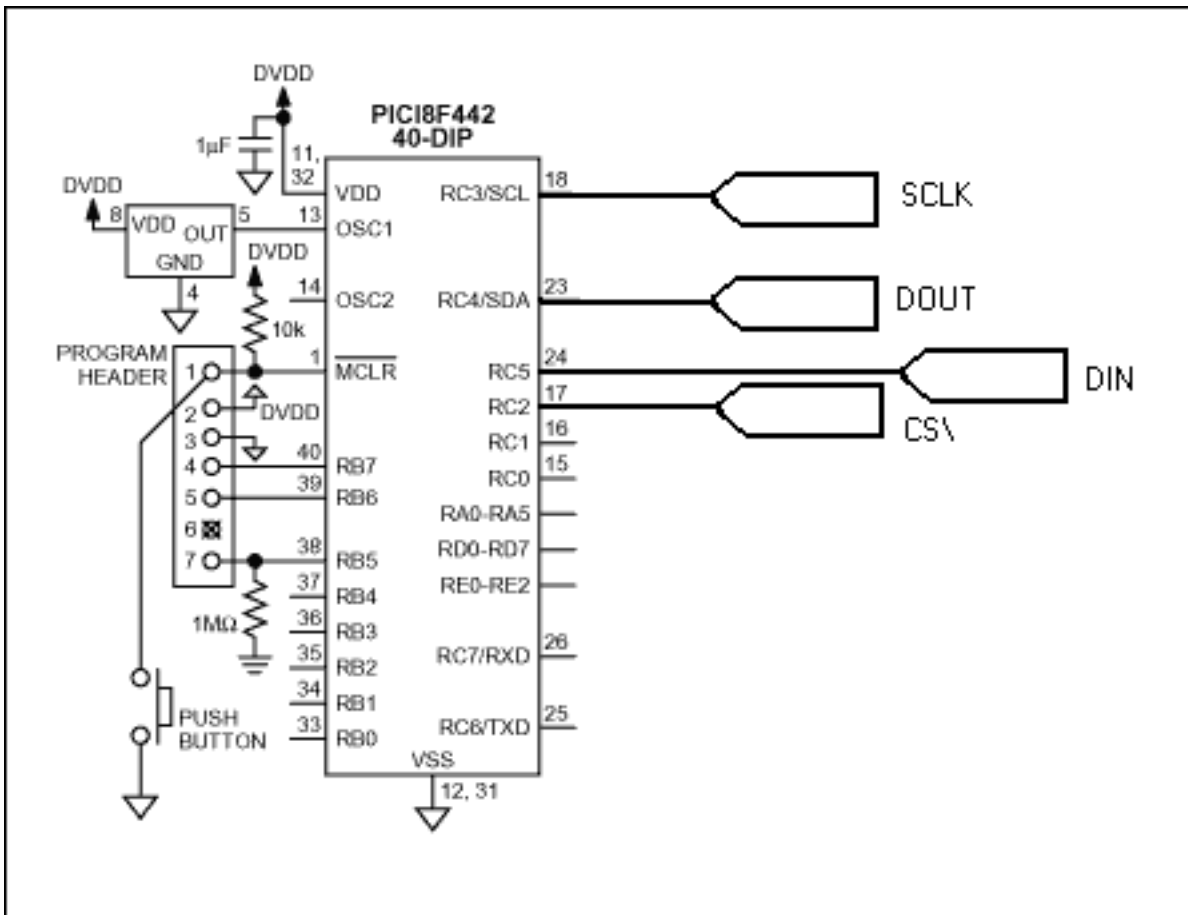

Figure 1. MAX5591 application schematic.

Analog and Digital Ground Planes

It is good practice to separate the analog and digital ground planes. An example of this is shown in **Figure 2**. Both ground planes should be connected together through a ferrite bead. Using a ferrite bead such as the TDK MMZ1608B601C to connect both grounds prevents the microcontroller's system clock and its harmonics from feeding into the analog ground. Knowing that the system clock of the PIC18F442 is 40MHz, the MMZ1608B601C was chosen for its specific impedance vs. frequency characteristics. **Figure 3** shows the impedance vs. frequency curve for the MMZ1608B601C.

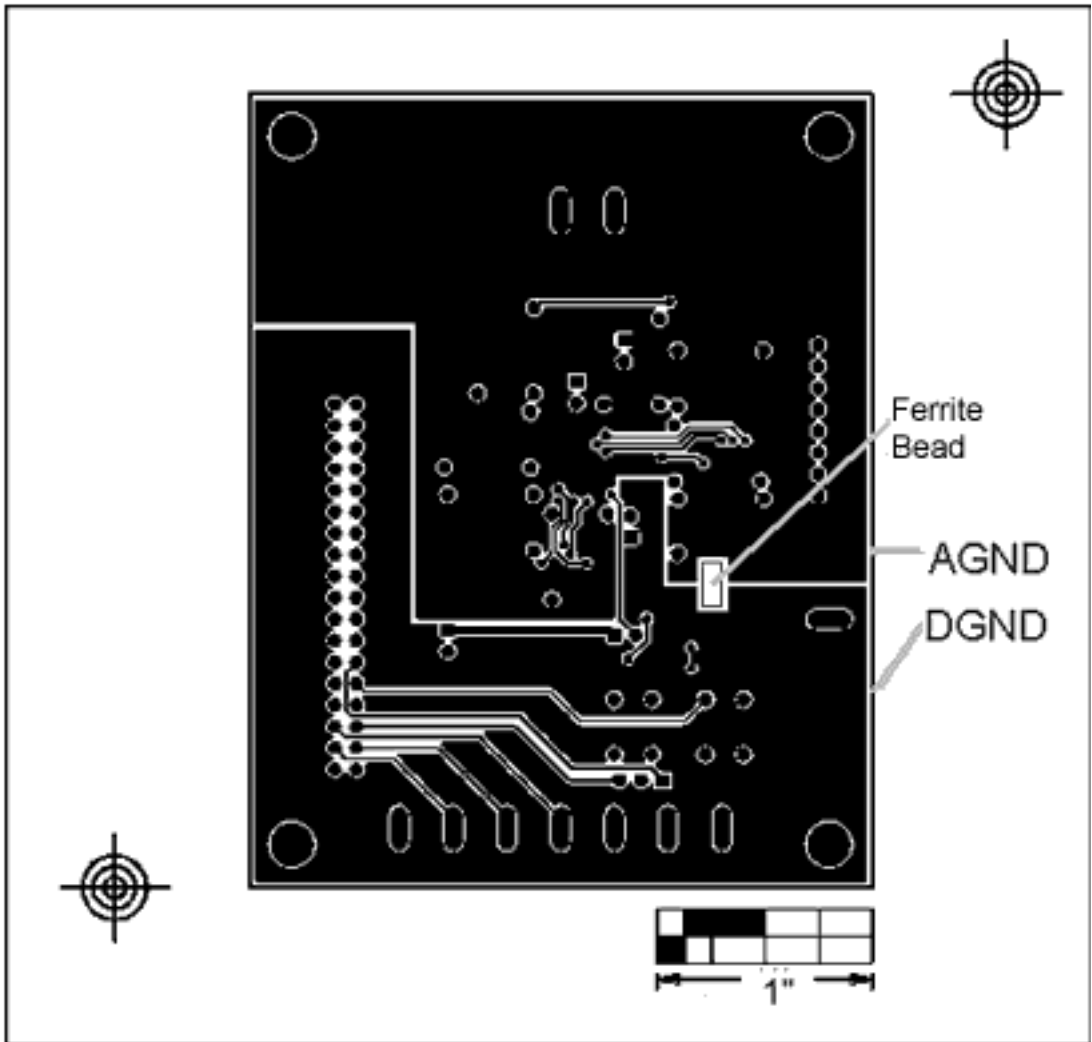

Figure 2. Separating analog and digital grounds.

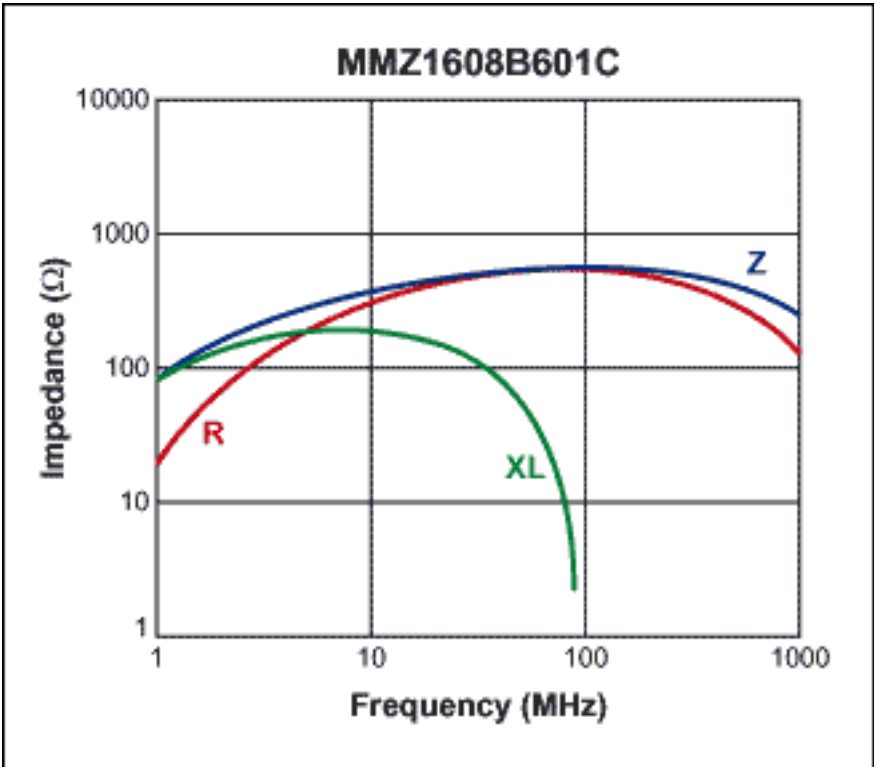

Figure 3. Impedance vs. frequency curve for the TDK MMZ1608B601C ferrite bead.

Firmware Overview

The example assembly program shown in Listing 1 initializes the MAX5591 using the PIC18F442's internal MSSP SPI peripheral. The PIC18F442's 40MHz system clock allows the MSSP to provide an SPI clock (SCLK) up to 10MHz. Table 1 shows the only configuration word required after power. Once the MAX5591 is initialized, the program constantly loads the DAC output registers with zero scale followed by full scale, as shown in Table 2. This constant loop results in a square wave that demonstrates the fast settling time of the MAX5591.

```

;*****
;
; Filename:      Listing 1 (Absolute Code Version)
; Date:         12/28/04
; File Version: 1.1
;
; Author:       Ted Salazar
; Company:      Maxim
;
;*****
;
; Program Description:
;
; This program interfaces the internal SPI MSSP
; (Peripheral) of the PIC18F442 to the MAX5591 SPI
; Data DAC. The program initializes the MAX5591
; and dynamically generates a 50% duty cycle square
; wave with a frequency of 500Hz.
;
;*****
;
; History:
; 12/14/04: Cleared timeout timer in HW_SPI_W_spi_data_W
; 11/28/04: Cleaned up code and comments.
; 10/18/04: Tested SPI DAC format
; 10/09/04: Initialized MAX5591
;*****
;
; Files required:      PIC18F442.INC
;
;*****
; radix hex           ;Default to HEX
; LIST P=18F442, F=180C2 ;Directive to define processor and file format
; #include <PIC18F442.INC> ;Microchip's Include File
;*****
;__alt equ 06         ; Asynchronous TX is at C6
;*****
; Configuration bits
; The _CONFIG directive defines configuration data within the .ASM file.
; The labels following the directive are defined in the PIC18F442.INC file.
; The PIC18F442 Data Sheet explains the functions of the configuration bits.
; Change the following lines to suit your application.

```

[Download](#)

Listing 1. This assembly example program interfaces to the MAX5591 using the PIC18F442's internal MSSP SPI peripheral.

Table 1. Configuration write command for setting the settling time to 3µs for all eight DACs.

SPI Line	C7	C6	C5	C4	C3	C2	C1	C0	D7	D6	D5	D4	D3	D2	D1	D0
DIN	1	0	1	1	1	0	0	0	1	1	1	1	1	1	1	1

Table 2. Load all DAC outputs commands. The first command sets all the DAC outputs to zero scale and the second command sets all the DAC outputs to full scale.

SPI Line	C3	C2	C1	C0	D11	D10	D9	D8	D7	D6	D5	D4	D3	D2	D1	D0
DIN (1 st)	1	0	1	0	0	0	0	0	0	0	0	0	0	0	0	0
DIN (2 nd)	1	0	1	0	1	1	1	1	1	1	1	1	1	1	1	1

Application Note 3439: www.maxim-ic.com/an3439

More Information

For technical support: www.maxim-ic.com/support

For samples: www.maxim-ic.com/samples

Other questions and comments: www.maxim-ic.com/contact

Automatic Updates

Would you like to be automatically notified when new application notes are published in your areas of interest?

[Sign up for EE-Mail™.](#)

Related Parts

MAX5590: [QuickView](#) -- [Full \(PDF\) Data Sheet](#) -- [Free Samples](#)

MAX5591: [QuickView](#) -- [Full \(PDF\) Data Sheet](#) -- [Free Samples](#)

MAX5592: [QuickView](#) -- [Full \(PDF\) Data Sheet](#) -- [Free Samples](#)

MAX5593: [QuickView](#) -- [Full \(PDF\) Data Sheet](#) -- [Free Samples](#)

MAX5594: [QuickView](#) -- [Full \(PDF\) Data Sheet](#) -- [Free Samples](#)

MAX5595: [QuickView](#) -- [Full \(PDF\) Data Sheet](#) -- [Free Samples](#)

AN3439, AN 3439, APP3439, Appnote3439, Appnote 3439

Copyright © by Maxim Integrated Products

Additional legal notices: www.maxim-ic.com/legal