

APPLICATION NOTE 254

## Switch-Mode Converter Starts With Full Load Connected

**Abstract:** The start-up circuit is composed of microprocessor ( $\mu\text{P}$ ) supervisory circuit MAX809L and charge pump circuit is used to monitor the boost converter output voltage. The high efficiency step-up controller MAX608 is used to boost output voltage and the charge pump circuit controlled by supervisory circuit MAX809L is used to connect the full load when the output voltage reaches its regulated level.

Operating from a 2-cell or 3-cell battery, the boost converter shown in **Figure 1** delivers as much as 500mA from its regulated 5V output. Following a start-up or brownout condition, however, the output and load remain disconnected until the output achieves regulation.

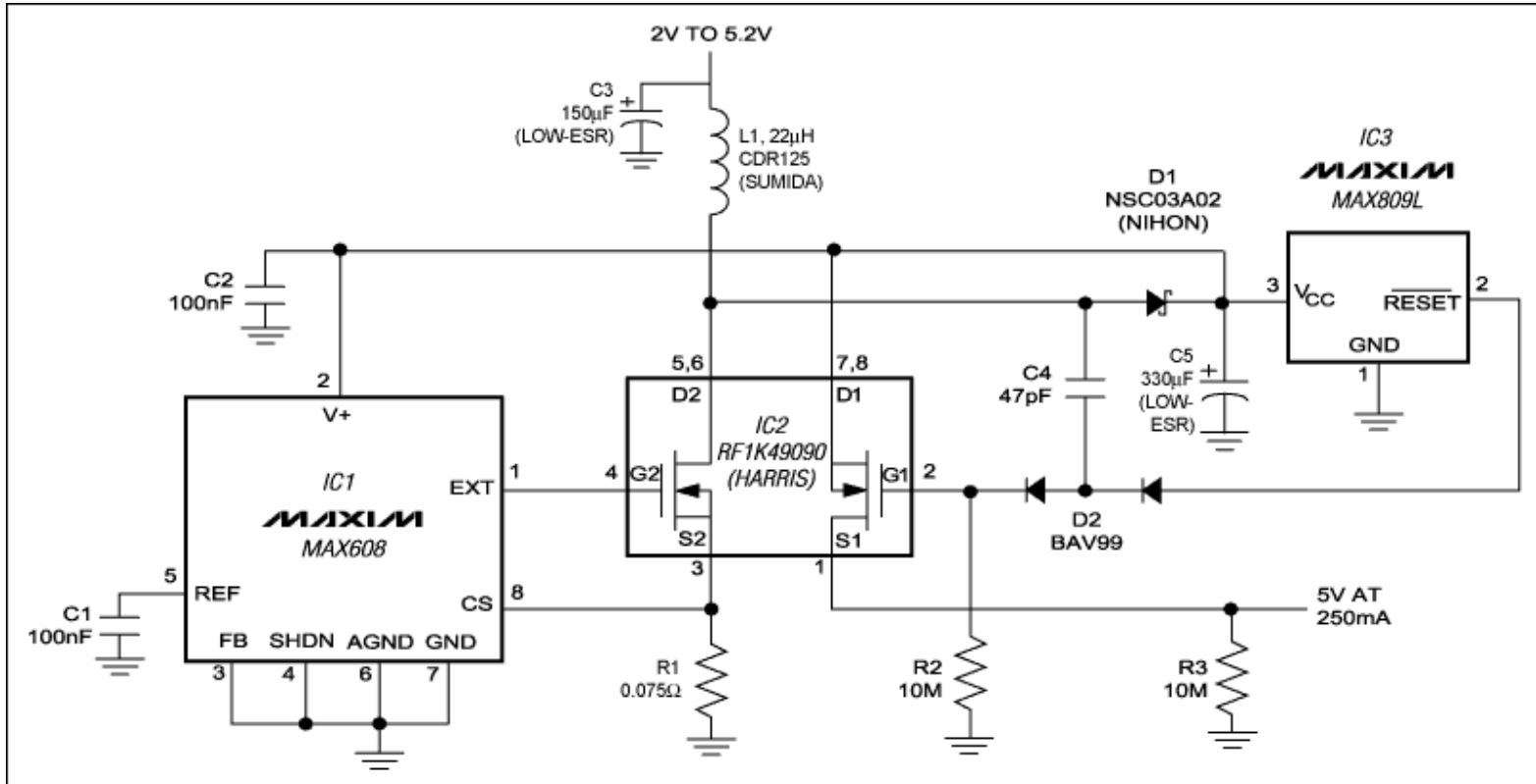

**Figure 1.** To ensure a full-load start-up, the extra circuitry in this regulated boost converter disconnects the load until the output voltage achieves regulation. IC1's V+ terminal (pin 2) provides power as well as feedback to the chip. This "bootstrapped" operation (in which the chip is powered from its own output) enables start-up from input voltages as low as +1.8V, unless a heavy load prevents start-up altogether.

Proper operation requires a gate-drive voltage sufficient to provide low on-resistance in the switching MOSFET, but at start-up this drive is limited to the battery voltage. The resulting high on-resistance in the MOSFET can prevent the converter output from rising to its specified level. On the other hand, connecting the output and load only after  $V_{OUT}$  is within tolerance allows the MOSFET to turn on fully with minimum on-resistance.

The N-channel MOSFETs of IC2 are each rated for 3.5A, 12V, and a  $0.05\Omega$  on-resistance in the "fully on" state. Device #2 (on the left) is the switching transistor, and Device #1 is a high-side load switch. Gate drive for the load switch comes from a charge pump (C4 and the dual diode D2) that is driven by the switching node at the bottom of L1. At start-up the  $\mu\text{P}$  supervisor (IC3) issues a reset (low output at pin 2) that prevents charging of C4.

When IC3's pin 3 rises above 4.65V, however, pin 2 goes high, enabling C4 to charge via the right-hand diode each time the switching node goes low. Each time it returns high, the C4 voltage adds to the output voltage, boosting the MOSFET gate (G1) to about 9.5V. This level is maintained by a charge on the gate-source capacitance. On start-up, therefore, the charge-pump output ramps up to about 4.5V, and then jumps to 9.5V when IC3's RESET output goes high. Only then does the high-side switch turn on and connect the load.

If IC3's 240ms power-up delay is too long, you can replace IC3 with another  $\mu\text{P}$  supervisor (MAX821) that lets you select the delay as 1ms, 40ms, or 200ms max. This boost converter circuit features pulse-frequency modulation (PFM), and therefore requires a minimum load of approximately  $5\mu\text{A}$  to ensure that the converter (and therefore the charge pump) continues to switch occasionally. In practice, this minimum load is provided by reverse leakage in the Schottky rectifier (D1), but if D1 is replaced by a low-leakage non-Schottky rectifier (or if you just want to guarantee the load), reduce the value of R3 to 1M $\Omega$ .

The circuit shown provides efficiencies greater than 80% while supplying 250mA with an input of 2.0V, or 500mA with an input of 2.7V. The Harris MOSFETs have a  $V_{GS(TH)}$  of 2.0V max, but by substituting a switch with lower  $V_{GS(TH)}$  (such as the Temic Si6946DQ) you can modify the circuit to start from battery voltages as low as 1.8V. (The Temic part, however, has a higher  $R_{DS(ON)}$ .)

A similar idea appeared in the 9/98 issue of *Electronics World & Wireless World*.

**More Information**

For technical questions and support: <http://www.maxim-ic.com/support>

For samples: <http://www.maxim-ic.com/samples>

Other questions and comments: <http://www.maxim-ic.com/contact>

**Related Parts**

MAX608: [QuickView](#) -- [Full \(PDF\) Data Sheet](#) -- [Free Samples](#)

MAX809L: [QuickView](#) -- [Full \(PDF\) Data Sheet](#) -- [Free Samples](#)

AN254, AN 254, APP254, Appnote254, Appnote 254

Copyright © by Maxim Integrated Products

Additional legal notices: <http://www.maxim-ic.com/legal>