

APPLICATION NOTE 1909

Tiny Light Sensor With Logic Output Draws Less Than 10 μ A

A light-sensing circuit that consumes very little power can serve as an automatic backlight sensor in portable instruments. This function is easily implemented with a logic gate or Schmitt-trigger inverter, but those approaches draw a considerable amount of supply current. The circuit IC1 (**Figure 1**) offers a different—and better—solution.

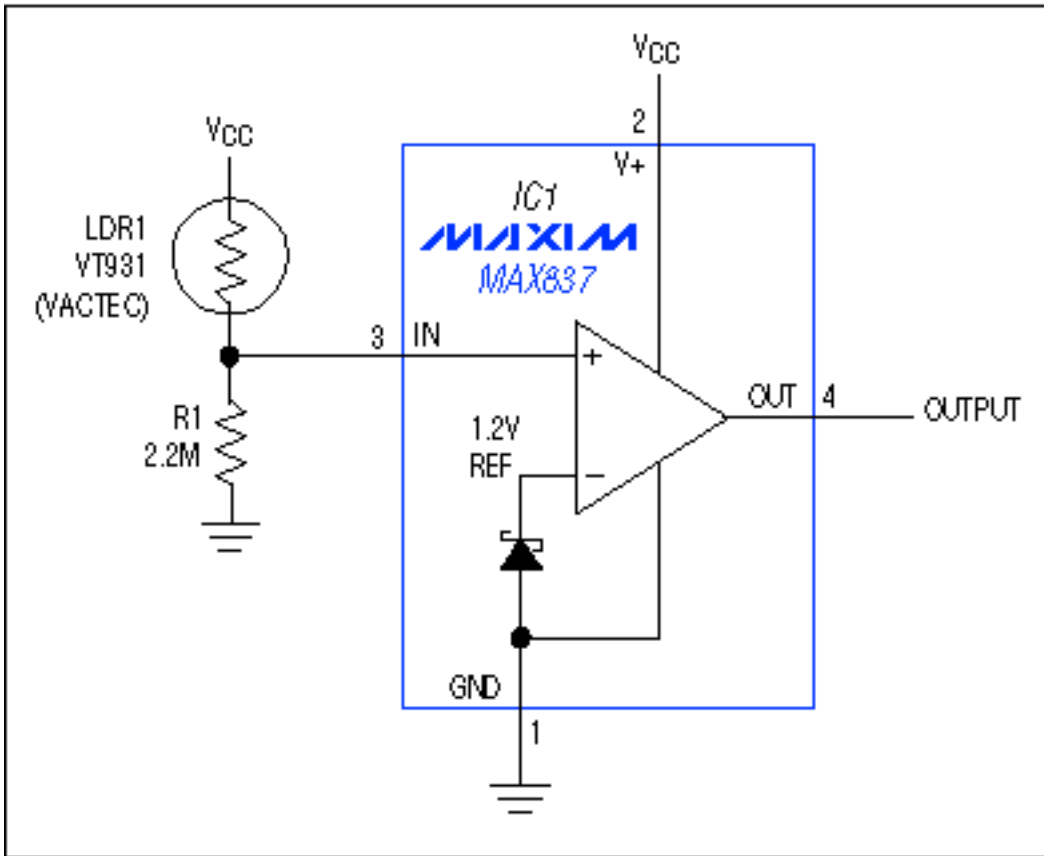

Figure 1. This light sensor provides a low-to-high output transition at a light level determined by the value of R1.

A logarithmic graph of supply current vs. supply voltage (**Figure 2**) illustrates a comparison. As expected for CMOS circuits, the 74HC inverter and 74HC14 Schmitt-trigger inverter draw very little current ($< 1\mu\text{A}$) when their inputs are near the supply rails. Near midscale, however, the 74HC04 at 5V draws more than 10mA! The 74HC14 is better, but still draws more than 0.5mA at midscale. These currents pose a problem because the midscale condition in a light-sensing circuit can persist for a long time.

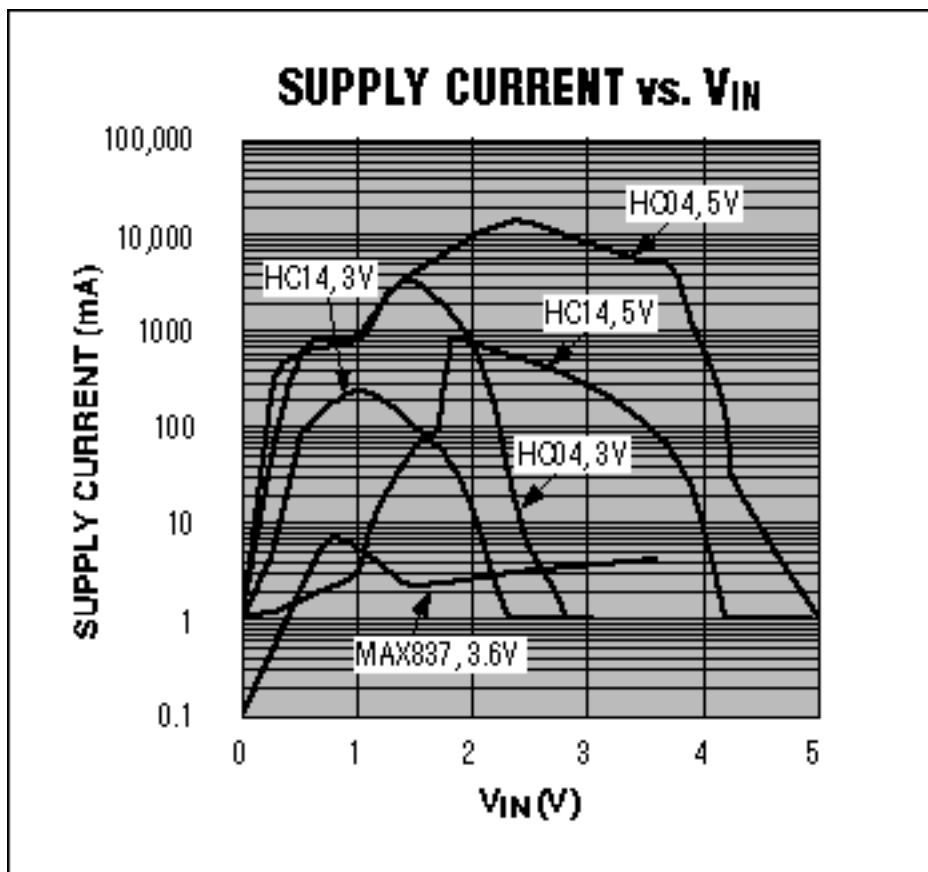

Figure 2. These curves compare the supply current drawn by IC1 of Figure 1 (the lowest curve, labeled MAX837, 3.6V) with that of alternative devices.

+3V power supplies reduce the supply currents by an approximate factor of three, but the currents are still significant. Adding hysteresis also helps, but there will remain a point just above or below the switching threshold at which these CMOS devices draw excessive class-A supply currents.

The lowest curve, representing the supply current for IC1, varies only slightly over the signal range and never exceeds 7 μ A. The external light sensor and bias resistor draw a maximum of 3 μ A with a +5V supply, so the circuit's total supply current, independent of light level, is less than 10 μ A. Unlike the other approaches, this circuit compares the light level (represented by a voltage on R1) with a fixed reference voltage rather than a loosely specified logic-switching threshold.

Supply voltage can range from +2.5V to +11V, with the supply current measuring several microamps at +11V. IC1 also comes in an open-drain version (MAX836) whose output (tied to a pull-up resistor) can exceed the supply voltage in a mixed-voltage system. If minimum power consumption is more important than size, choose the MAX931 comparator/reference IC. It comes in a shrink SO-8 package called μ MAX[®] (versus the MAX837 SOT package), but its maximum supply current is only 3 μ A. The built-in hysteresis of the MAX837 obviates the need for external hysteresis resistors.

A similar idea appeared in the April 6, 1998 issue of *Electronic Design*.

Application Note 1909: www.maxim-ic.com/an1909

More Information

For technical questions and support: www.maxim-ic.com/support

For samples: www.maxim-ic.com/samples

Other questions and comments: www.maxim-ic.com/contact

Keep Me Informed

Preview new application notes in your areas of interest as soon as they are published. Subscribe to [EE-Mail - Application Notes](#) for weekly updates.

Related Parts

MAX837: [QuickView](#) -- [Full \(PDF\) Data Sheet](#) -- [Free Samples](#)

AN1909, AN 1909, APP1909, Appnote1909, Appnote 1909

Copyright © by Maxim Integrated Products

Additional legal notices: www.maxim-ic.com/legal