

APPLICATION NOTE 1794

Interfacing Digitally Controlled Pots and Resistors to Laser Drivers

Abstract: This application brief describes the two topologies used to bias optical laser drivers (open loop and closed loop) and demonstrates examples using the DS1847 digital potentiometer and the MAX3273 laser driver. A laser module designer can use a fixed resistor, mechanical pot, digital pot, or a digital-to-analog converter (DAC) to control the laser driver's modulation and bias currents. The advantages of a programmable method (POT or DAC) are that the manufacturing process can be automated and digital control can be applied (e.g., to compensate for temperature). Using POTs can be a more simple approach than a DAC. There can be a slight cost advantage to using a POT, but this is usually not significant relative to other pieces of the design. Using a DAC can offer advantages, including improved linearity (translating to ease of software implementation and ability to hit the required accuracy), increased board density, a wider range of resolutions, a better optimization range, ease of use with a negative voltage laser driver, and unit-to-unit consistency.

The different modes of electrical interface between a laser driver and the digitally controlled potentiometers and resistors that control it are reviewed in the context of open- and closed-loop operation. The objective in these fiber-optic systems is to vary the amplitude of light using the laser driver's bias and modulation circuits, causing the optical power to swing between two levels (P0 and P1).

Open-Loop Topologies

In the bias-control topology of **Figure 1a**, the variable resistor sets a current (I_1) that is amplified and fed to a common-cathode laser diode (or sunk from a common-anode type). The most common voltage across the resistor is 1.2V, which is derived from a bandgap reference internal to the laser driver. I_1 ranges from microamperes to a few milliamperes, and I_2 ranges from tens of milliamps to 100mA. For some applications in which the resistor sources current, it can be connected to a fixed reference or to the supply instead of ground.

Figure 1b shows a low-side circuit (control with respect to ground) in which the input voltage V_1 sets an internal current I_1 , which is amplified to a level of I_2 for driving the laser by either sourcing or sinking current. The potentiometer in this circuit is ideal for the high-input impedance seen by V_1 . (In the Figure 1a configuration, a variable resistor is more appropriate.)

For high-side control (**Figure 1c**), a decreasing control voltage (V_1) causes an increase in I_1 and in the laser-drive current I_2 . Thus, to increase the laser output's average optical power, resistance has to decrease in Figure 1a, V_1 has to increase in Figure 1b, and V_1 has to decrease in Figure 1c.

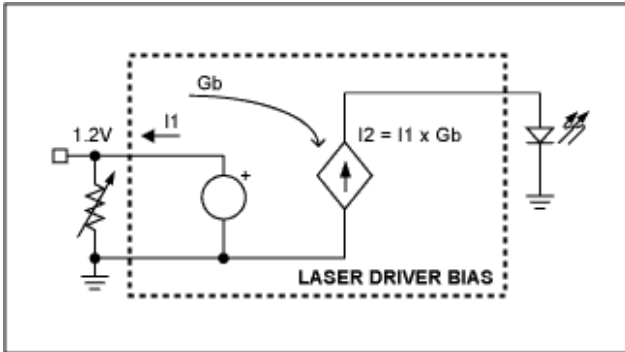

Figure 1a.

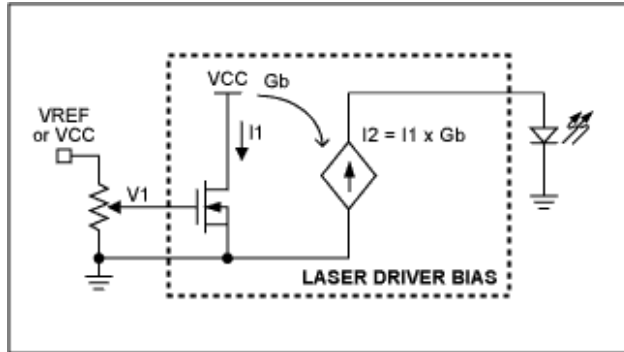

Figure 1b.

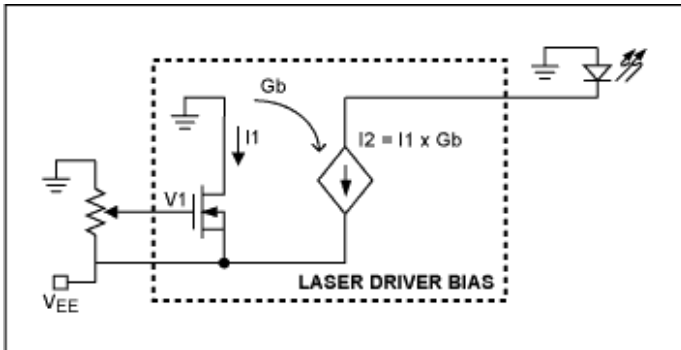

Figure 1c.

Figure 1. Open-loop methods for control of laser-bias current include (a) low-side control (laser-cathode grounded) with a variable resistor, or (b) a potentiometer driving a high-impedance input, and (c) high-side control (laser anode grounded) with a negative supply.

Circuit configurations for control of the laser-modulation level (**Figures 2a and 2b**) are similar to those for control of the bias current. Amplitude modulation of the data carrier produces a switched current. To increase the peak-to-peak amplitude of emitted light, lower the variable resistance in Figure 2a or increase V_3 in Figure 2b. (These diagrams show the injection of bias current into the laser as well as modulation current.) In Figure 1b and 2b, note that the input stage of the laser driver IC, which carries I_1 or I_3 , can be a bipolar npn transistor.

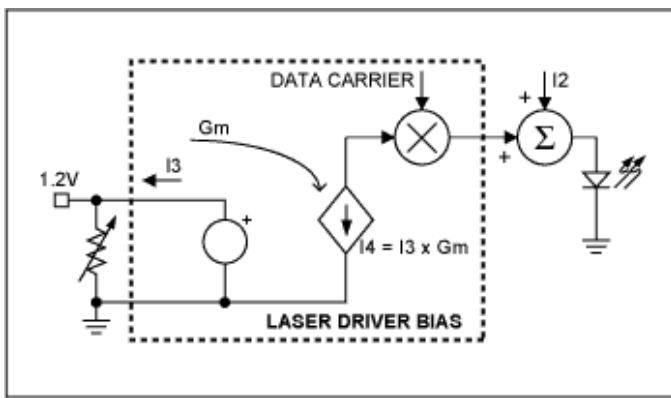

Figure 2a.

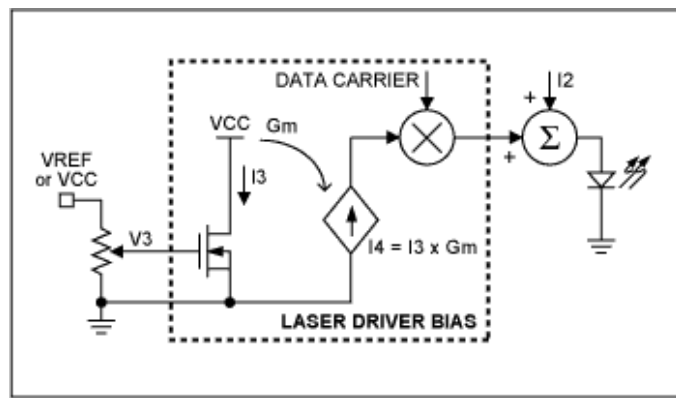

Figure 2b.

Figure 2. Circuits for low-side control of laser-modulation current are similar to those for control of bias current in Figures 1a and 1b.

Closed-Loop Topologies

Average power control (APC) is a common means for regulating the average optical output of a laser. The laser is controlled by a photodiode monitor in the feedback path, resulting in closed-loop control of the laser light.

Less common are closed-loop modulation-control circuits. Figures 3a and 3b show a resistor interface to such laser drivers.

In Figure 3a, the laser-bias current is an amplified version of the error between the current fed back from the photodiode monitor (I_{fa}) and a reference current (I_1). As the variable resistance decreases, I_1 increases. Because I_{fa} tracks I_1 , the average optical power also increases.

Figure 3b is a simplified representation of closed-loop modulation. Comparing a feedback signal derived from the photodiode current (I_{fb}) with a reference current (I_3) produces an error that is amplified and used to modulate the data-carrier amplitude, resulting in a switched current. As resistance decreases, the peak-to-peak optical power increases. Bias current (I_2) is included in Figure 3b to complete the picture.

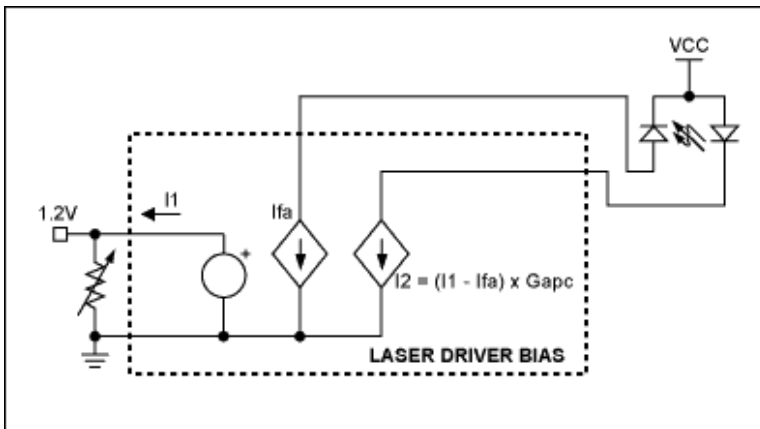

Figure 3a.

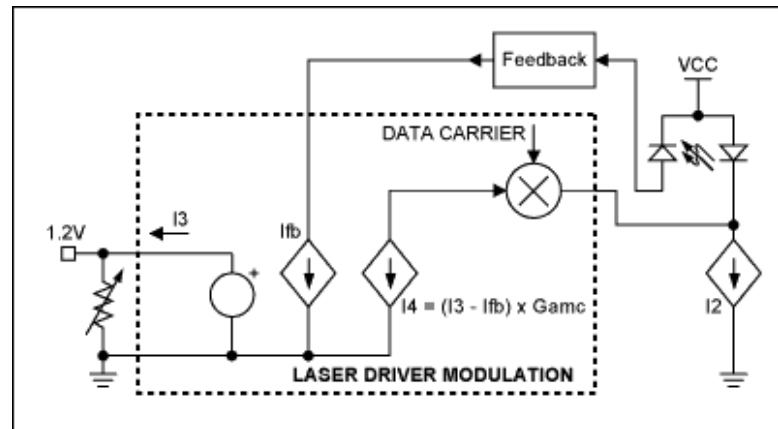

Figure 3b.

Figure 3. (a) A photodiode monitor allowing closed-loop laser control can also accommodate (b) control of the modulation current.

Example: The MAX3273/DS1847 Pair

To interface laser driver MAX3273 to the DS1847 digitally controlled resistor, first determine your average optical power (P_{avg}) and peak-to-peak optical modulation power (P_{mod}).

P_{avg} is regulated by an APC loop around the laser driver (Figure 3a), and depends directly on I_1 and the photodiode's responsivity in mA/mW. The DS1847 resistor sets I_1 equal to $1.2/R$. Next, $P_{avg} = I_1/\text{responsivity} = 1.2/(\text{responsivity} \times R)$

Note the dependence of R on the photodiode characteristic in achieving the required average power. Therefore, to achieve reasonable design yields, it is recommended that the designer know the statistical distribution of this parameter as well as its temperature dependence. For example, a DFB laser (SLT2170-LN) with $P_{avg} = 0.4\text{mW}$ produces a photodiode current that ranges upward from 0.15mA , which in turn calls for $<8\text{k}\Omega$ resistance. Resistor 1 internal to the DS1847 should be used for the APC function.

P_{mod} is not regulated within the laser driver, and therefore runs open loop. It is controlled by a resistor that sets I_3 (see Figure 2a). In turn, I_3 sets the peak-to-peak modulation current, which is added to the bias current and injected into the laser. As a result, the laser-light output consists of a DC component and a pulsed component. The pulsed component (P_{mod}) depends on the laser quantum efficiency (η) expressed in mW/mA, the gain G_m (Figure 2a), and I_3 (which equals $1.2/R_{mod}$). Thus, $P_{mod} = 1.2 \times G_m \times \eta/R_{mod}$.

Again, R_{mod} depends on η for a given P_{mod} , so it is important to understand the variation of η . For a system that includes the same laser (SLT2170-LN) with $P_{mod} = 0.6\text{mW}$, $G_m = 165$, and $\eta = 0.06$, the required resistance is less than $20\text{k}\Omega$. The DS1847's resistor 0 should be used for the modulation function.

The DS1847 includes look-up tables for temperature compensation (refer to Maxim/Dallas Semiconductor [App Note 167: Considerations for the DS1847/1848 Look-Up Tables](#)). Such compensation is essential for the APC and modulation controls. In APC mode the table serves to offset the temperature dependence of photodiode responsivity, which varies as much as $\pm 1.5\text{dB}$ (about 40%) per the SLT2170-LN data sheet. As for modulation, the corresponding table serves primarily to offset temperature dependence of the laser efficiency η , which can vary as much as $\pm 3\text{dB}$ (a factor of 2).

An added benefit of look-up tables is their help in compensating the temperature dependence of laser-driver gain, resistor value, and other parameters in the application. The DS1847 resistor value is characterized at various temperatures in the Dallas factory. The result fits into an equation, whose coefficients are stored in registers for use during calibration at the customer site (refer to Application Note 167).

To illustrate some of the concepts described in the previous paragraph, **Figures 4a, 4b,** and **4c** show typical characteristics in lasers and photodiodes after they are temperature compensated with look-up tables.

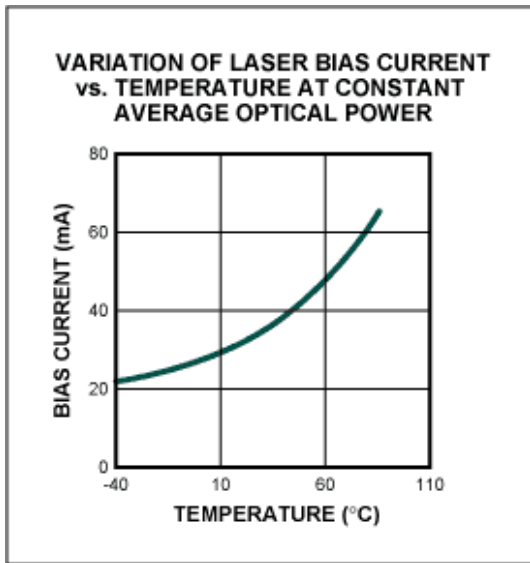

Figure 4a. A laser bias current variation is implemented with a look-up table if an open-loop operation such as Figure 1a is used.

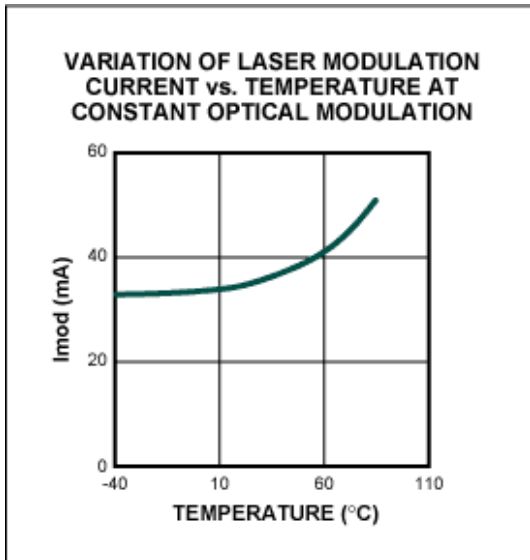

Figure 4b. A peak-to-peak laser modulation current variation is implemented with a look-up table if an open-loop operation, such as Figure 2a, is used.

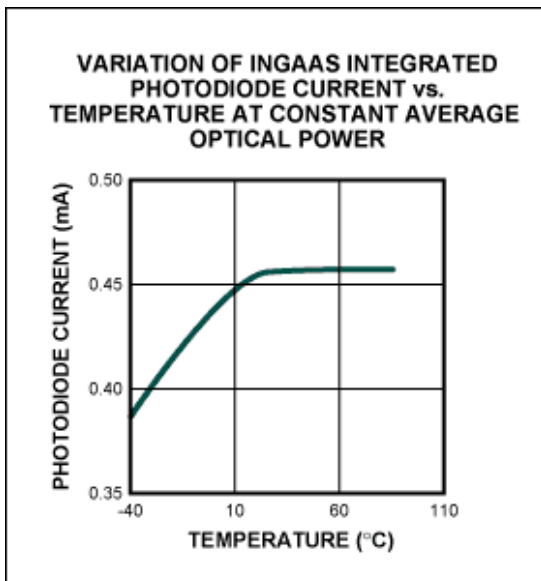

Figure 4c. An integrated photodiode current variation is implemented with a look-up table if a closed-loop operation (APC), such as Figure 3a, is used.

Application Note 1794: <http://www.maxim-ic.com/an1794>

More Information

For technical questions and support: <http://www.maxim-ic.com/support>

For samples: <http://www.maxim-ic.com/samples>

Other questions and comments: <http://www.maxim-ic.com/contact>

Related Parts

DS1847: [QuickView](#) -- [Full \(PDF\) Data Sheet](#) -- [Free Samples](#)

MAX3273: [QuickView](#) -- [Full \(PDF\) Data Sheet](#) -- [Free Samples](#)

AN1794, AN 1794, APP1794, Appnote1794, Appnote 1794

Copyright © by Maxim Integrated Products

Additional legal notices: <http://www.maxim-ic.com/legal>