

APPLICATION NOTE 1768

Tracking Advances in VCO Technology

Abstract: This application note tracks the history of voltage-controlled oscillators (VCOs) since approximately 1910 and provides examples of VCO integration in RF ICs. It traces the technology, and discusses evolution of product performance and size. Future trends are projected.

Introduction

Voltage-controlled oscillators (VCOs) are commonly found in wireless systems and other communications systems that must tune across a band of frequencies. VCOs are available from a wide range of manufacturers in a variety of package styles and performance levels. Modern surface-mount and radio-frequency integrated-circuit (RFIC) VCOs, however, owe their heritage to engineering developments that began almost a hundred years ago. Improvements in VCO technology have continued throughout that time, yielding ever-smaller sources with enhanced phase noise and tuning linearity.

Evolution of the Oscillator Circuit

Oscillators have been essential components since Edwin Armstrong discovered the heterodyne principle.* In this application, an oscillator feeds sinusoidal signals to a nonlinear mixing element to effect frequency translation by multiplying the oscillator's signals with other input signals. Of course, Armstrong realized that what he needed to control the frequency translation was an electrical circuit, which produced a stable sinusoidal time-varying voltage (or current) with a corresponding frequency. He discovered around the same time that an Audion (an early vacuum tube) could be configured to produce an oscillation, and he effectively devised the first electronic oscillator** (rather than the crude spark-gap oscillators used in early wireless transmitters).

In retrospect, Armstrong started a revolution in oscillator technology that quickly made spark transmitters obsolete, thus leading to the development of high-performance radio receivers. From the time of Armstrong's discoveries in the 1910s to the modern era, VCO technology has progressed from vacuum tube oscillators to transistor oscillators, to oscillator module solutions, and finally to today's RFIC-based oscillators. The face of VCO technology is again rapidly changing, and soon in many systems will only resemble early oscillators in basic topology and/or mathematically.

Armstrong's discovery was soon improved upon by Ralph V.L. Hartley with his invention of oscillator circuit topology (**Figure 1**). Hartley used improvements in vacuum-tube technology and devised an oscillator circuit in which the vacuum tube acted as an amplifying device with inductive feedback applied to create a regenerative oscillation. The frequency of oscillation was established by the coil inductance and the circuit capacitance. This circuit was a breakthrough in the generation of a sinusoidal signal; it provided a much greater range of possible frequencies simply by varying the value of the coil or capacitor. The Hartley oscillator circuit was popular in transmitters and was quickly adapted for use in World War I. Both transmitters and receivers used the new tube-based oscillator circuit. Oscillator circuit innovations proliferated, and led to the predominant circuit topologies still used today, such as Hartley, Colpitts, Clapp, Armstrong, Pierce, and other topologies.

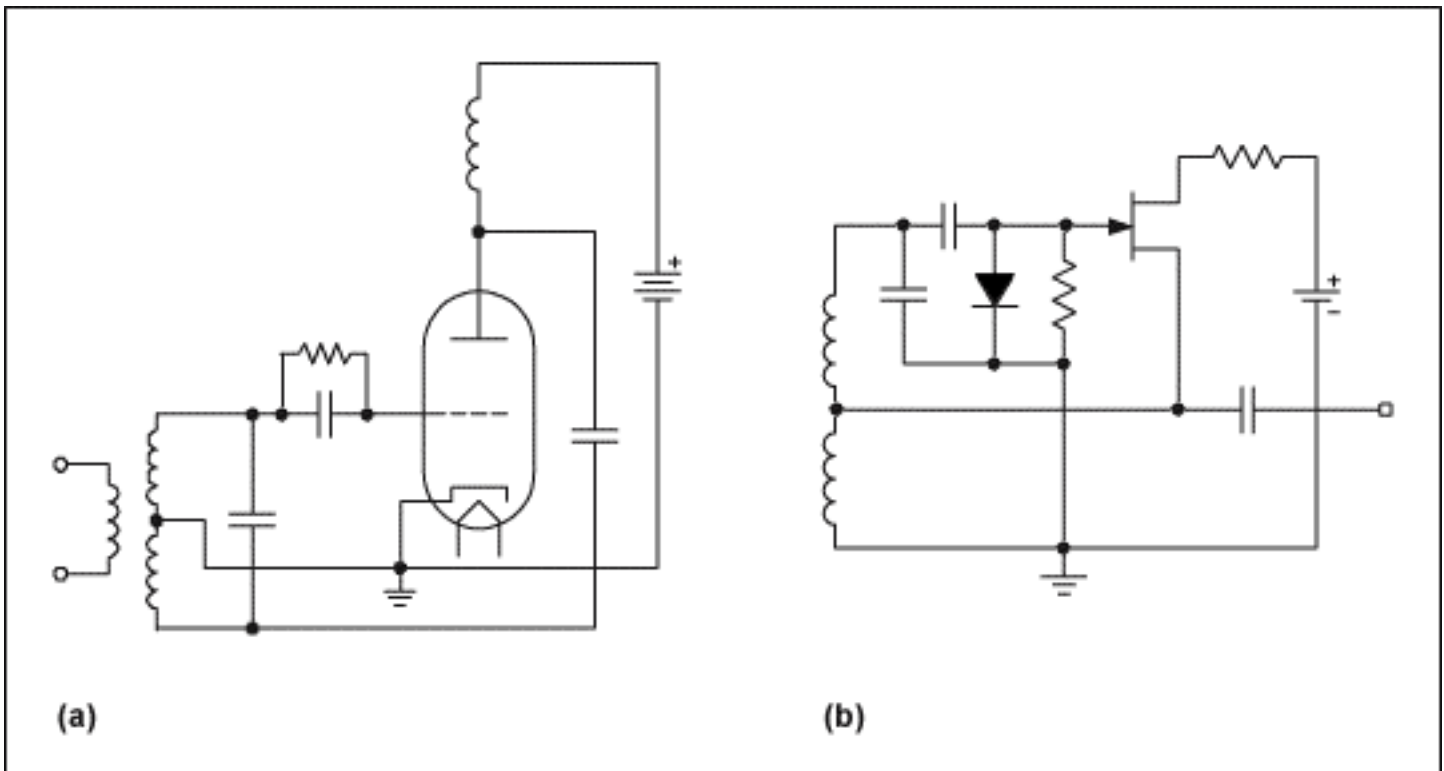

Figure 1. Examples of the Hartley oscillator: (a) triode implementation and (b) JFET implementation.

In Armstrong's superheterodyne receiver principle, input signals are mixed with oscillator signals to produce a constant intermediate frequency (IF). To maintain the constant IF, the oscillator must change frequency as the input signals change frequency. With a variable-frequency oscillator, it was possible to tune the frequency translation circuit to a wide range of input RF signals and, therefore, enable multichannel communications, such as amplitude-modulated (AM) radio. Such variable-frequency oscillators were an adaptation of the basic resonant-circuit oscillators, in which one of the resonant elements (an inductor or capacitor) would vary. Most often, the capacitor was varied. High-quality variable capacitors were constructed from ganged multiplate metal air-gap capacitors.

As radio technologies advanced, sustained innovation occurred in the implementation of oscillator circuits. Engineers devised countless types of coils, variable capacitors, feedback techniques, and vacuum tubes to implement oscillator and frequency-conversion circuits. Many elaborate and elegant schemes were devised to provide precise, high-quality tuning of the oscillator frequency through a mechanical dial on the front of the radio. **Figure 2** is a picture of a recreated vintage 1929 Hartley-style transmitter (as recreated by Ham radio enthusiast W9QZ). Like many early electronic implementations, the circuit was bulky and expensive, and required high supply voltages.

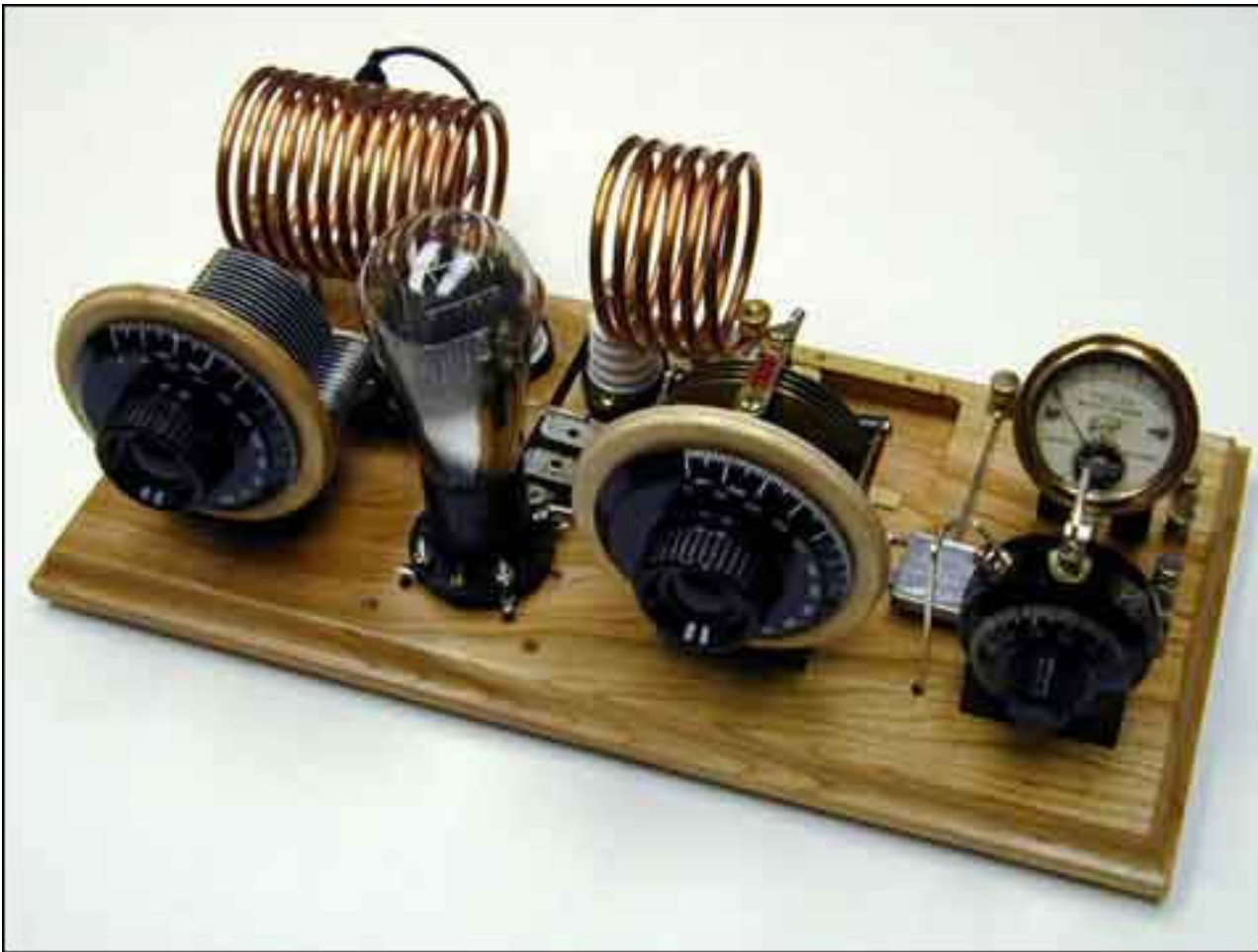

Figure 2. Vintage 1929 Hartley-style transmitter.

The Bipolar Transistor and Varactors

The vacuum-tube oscillator was widely employed for many years in commercial and military radio receiver applications, such as AM and frequency-modulated (FM) radios, television, and military voice communications. However, the discovery of semiconductor amplifying devices, such as the transistor and the varactor diode, led to the next dramatic change in VCO technology.

The first bipolar transistor was discovered in the late 1940s at Bell Laboratories (Holmdel, NJ), and transistors became available in the 1950s as replacements for vacuum tubes. The new transistors were smaller and consumed less power than tubes, had lower operating voltage requirements, and ultimately cost less. The transistor replaced the vacuum tube as the active element in oscillators, and significantly changed the practical implementation established for oscillator topologies.

Arguably, the introduction of the varactor diode (with a voltage-variable capacitance arising from a reverse-biased PN junction) had a greater impact on the direction of VCOs than the transistor. In the early 1960s, a great deal of research was performed on varactor technology, and varactors rapidly displaced mechanically adjustable components as the variable-capacitance element in VCOs. Varactors proved invaluable in the development of phase-locked-loop (PLL) circuits for precise electronic control of frequency sources. The rapid growth of television during that time contributed greatly to the migration to varactor- and transistor-based VCOs. Cost-effective, low-power, high-quality VCOs with inherent electronic tuning and easily reconfigurable frequency ranges were now possible. Discrete-transistor and varactor-based VCOs dominated electronic designs of the 1960s through 1980s. But, in the 1980s two new technologies impacted VCO developments: modular approaches and monolithic VCO integrated circuits (ICs). **Figure 3** shows a timeline illustrating the development of VCO technologies over the past 80 years.

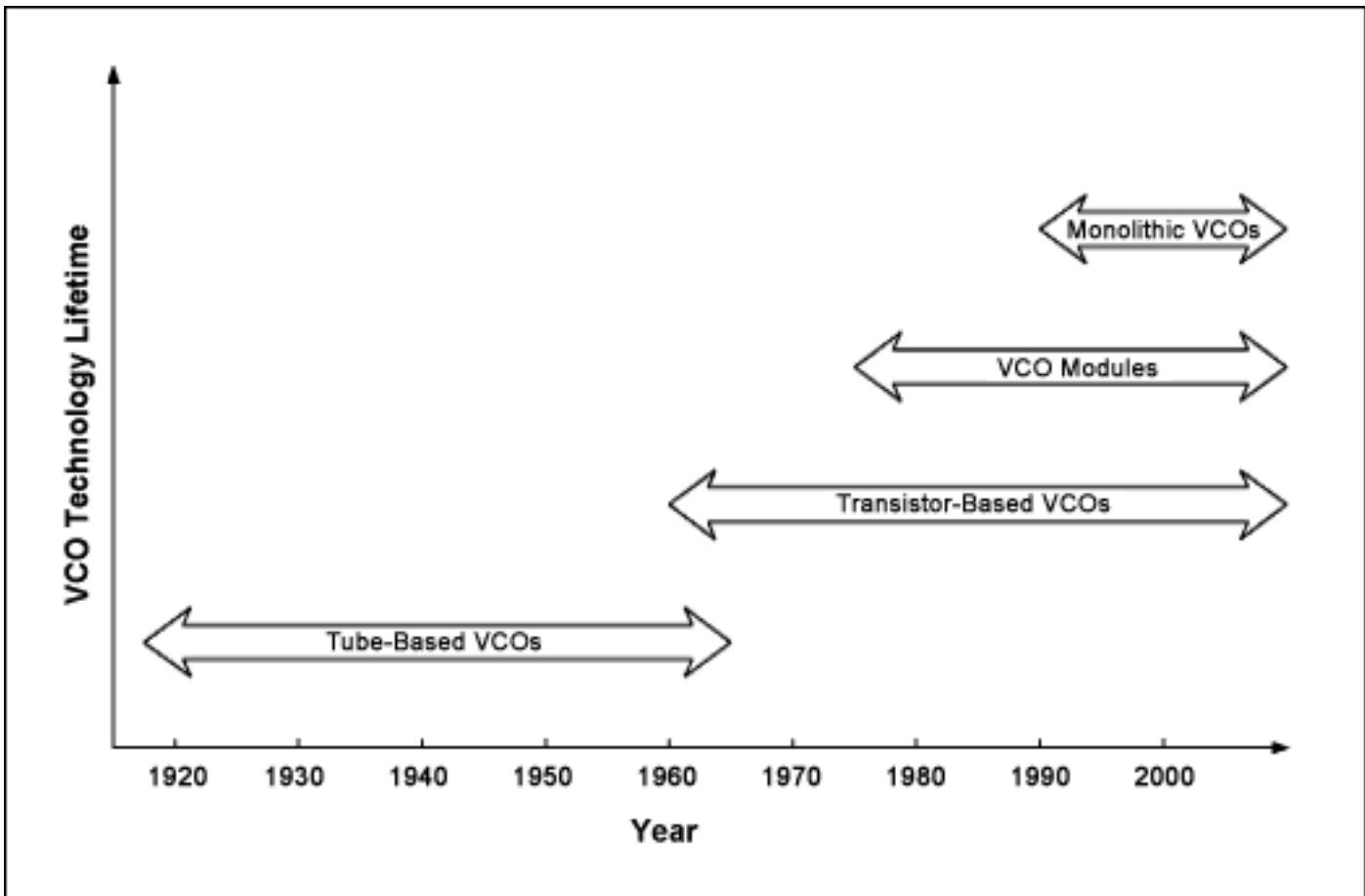

Figure 3. Chart of VCO technology lifetimes versus year.

The Modular Approach

The shrinking sizes of varactors, capacitors, and inductors made possible VCOs in module form. A VCO module is essentially a miniature version of a discrete-component oscillator constructed on a substrate that is mounted into a metal housing. The module is self-contained and requires only connections to ground, the supply voltage, the tuning voltage, and the output load. Such modules first appeared in the 1960's primarily for military applications. They were fairly large (several square inches) and relatively expensive. Discrete transistor and varactor implementations of VCOs were still used in commercial products. It was not until the emergence of mobile telephony that a commercial market emerged for VCO modules.

Although discrete VCOs could be custom designed to any frequency and tuning range, they typically required labor-intensive production adjustment of the frequency-setting elements to compensate for component variations. In addition, discrete VCOs needed good shielding to minimize emissions and reduce pulling effects. But with the growing sales of mobile telephones in the late 1980s and early 1990s, demand increased for "canned" oscillator modules. Some Japanese companies, becoming increasingly proficient in miniaturization, developed small, cost-effective VCO modules for mobile telephones. As new wireless applications emerged, VCO module manufacturers developed products with frequency plans unique to each application. As surface-mount components became progressively smaller (1206, 0805, 0603, 0402, 0201), new smaller, lower-cost VCO modules were developed. **Figure 4** illustrates the size reduction over time of the "typical" state-of-the-art commercial VCO module.

Today, these various design improvements have culminated in compact (4mm × 5mm × 2mm) modules that sell for close to \$1.00 (USD) in high volumes. This 15-year cycle of shrinking VCO module volume was a truly amazing reduction in size, and satisfied the demanding space constraints imposed by the new mobile wireless devices, such as cellular phones. Yet, an even smaller and more cost-effective VCO technology would emerge by the end of the 1990s: monolithic VCO IC technology.

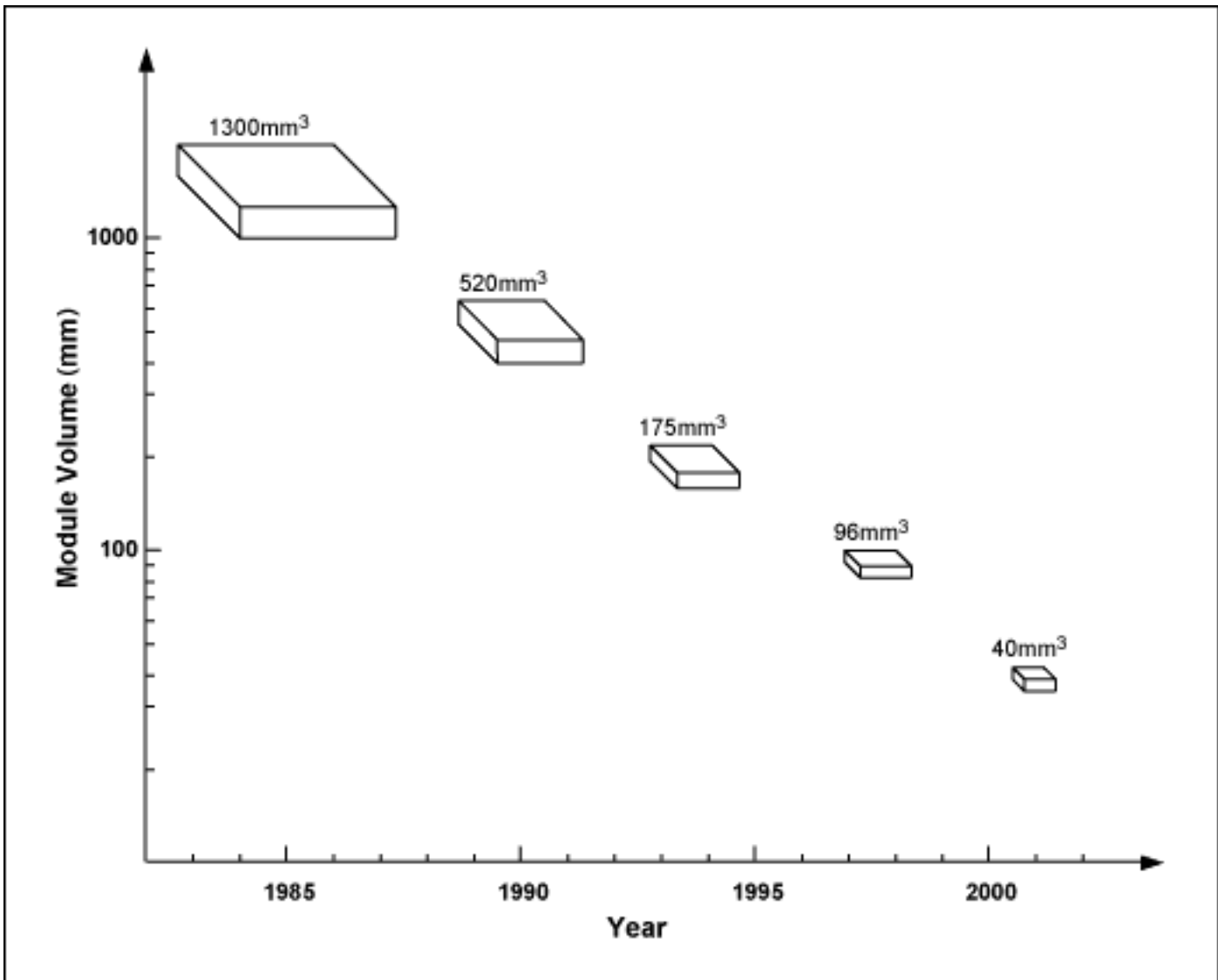

Figure 4. VCO module size scaling vs. time.

Monolithic VCOs

Monolithic VCO technology is defined as a VCO implementation in which all the circuit elements of an LC (inductance-capacitance) VCO (i.e., transistors, capacitors, resistors, inductors, and varactor diodes) are integrated on one chip. As in a VCO module, the devices are configured to form a complete VCO, requiring only connection to the power supply, ground, output, tuning input, and any digital control lines. (**Note:** Voltage-controlled ring oscillator circuits have been excluded from this definition of VCOs, as their phase noise is much poorer and thus precludes their use in most radio systems.)

The first instance of a monolithic VCO coincided with the development of Gallium Arsenide (GaAs) IC technology and monolithic microwave ICs (MMICs). The monolithic VCO emerged in the literature^{1,2} in the early 1980s during a period of intense research into commercial and military applications for MMICs (funded largely by the U.S. DARPA MIMIC program). Early MMIC VCOs were fabricated with GaAs IC processes, using 2in-diameter wafers. Those MMIC VCOs were not particularly area efficient and, therefore, were not cost effective. Generally, those VCOs operated at multi-GHz frequencies consistent with the target applications, satellite receivers and radar systems.

Most of the early monolithic GaAs VCOs developed by the DARPA MIMIC research had little impact on commercial markets. Silicon IC technology was still relegated to low frequencies during the 1980s and lacked the bandwidth needed for gigahertz-frequency monolithic VCOs. But by the 1990s, silicon IC technology had been developed with sufficiently high transition frequencies (f_T) and suitable monolithic components (high-Q inductors, and high-frequency capacitors and varactor diodes) to enable development of higher-frequency silicon monolithic VCOs.

Meanwhile, wireless markets had emerged with sufficient size and growth potential to spur the demand for low-cost VCOs in the 800MHz to 2500MHz bands.

Prior to these developments in the 1990s, most commercial radio systems operated at low frequencies so construction of a monolithic VCO IC was impractical; on-chip inductor values were simply too large. The first apparent instance of a silicon monolithic VCO IC in the literature is from the University of California at Berkeley in 1992.³ That VCO employed a unique, unorthodox topology: the frequency was varied by electrically "interpolating" between two separate resonant circuits. Nonetheless, it was still technically an implementation of monolithic silicon VCO IC technology. Arguably, this work and further research by Professor Robert Meyer and his graduate students at the Berkeley campus appears to have ushered in a period of increased research on monolithic VCOs.

By 1995, work on silicon monolithic VCO ICs was being reported in the technical literature by researchers at leading universities.^{4,5} In these reports, researchers disclosed some of the first examples of modern, monolithic LC resonator VCO ICs. During 1996 to 1997, many papers appeared describing work on different implementations of monolithic VCOs.⁶⁻¹¹ This period effectively marked the emergence of the commercially-viable monolithic VCO ICs.

The monolithic VCO ICs were being developed in both high-frequency bipolar transistor IC technology and silicon CMOS IC technology. Academic researchers typically used CMOS technologies to take advantage of the widespread availability of the IC technology, while industrial researchers used RFIC-specific bipolar/BiCMOS process technology. **Figure 5** shows a typical monolithic VCO circuit implemented in both CMOS and bipolar/BiCMOS process technologies.

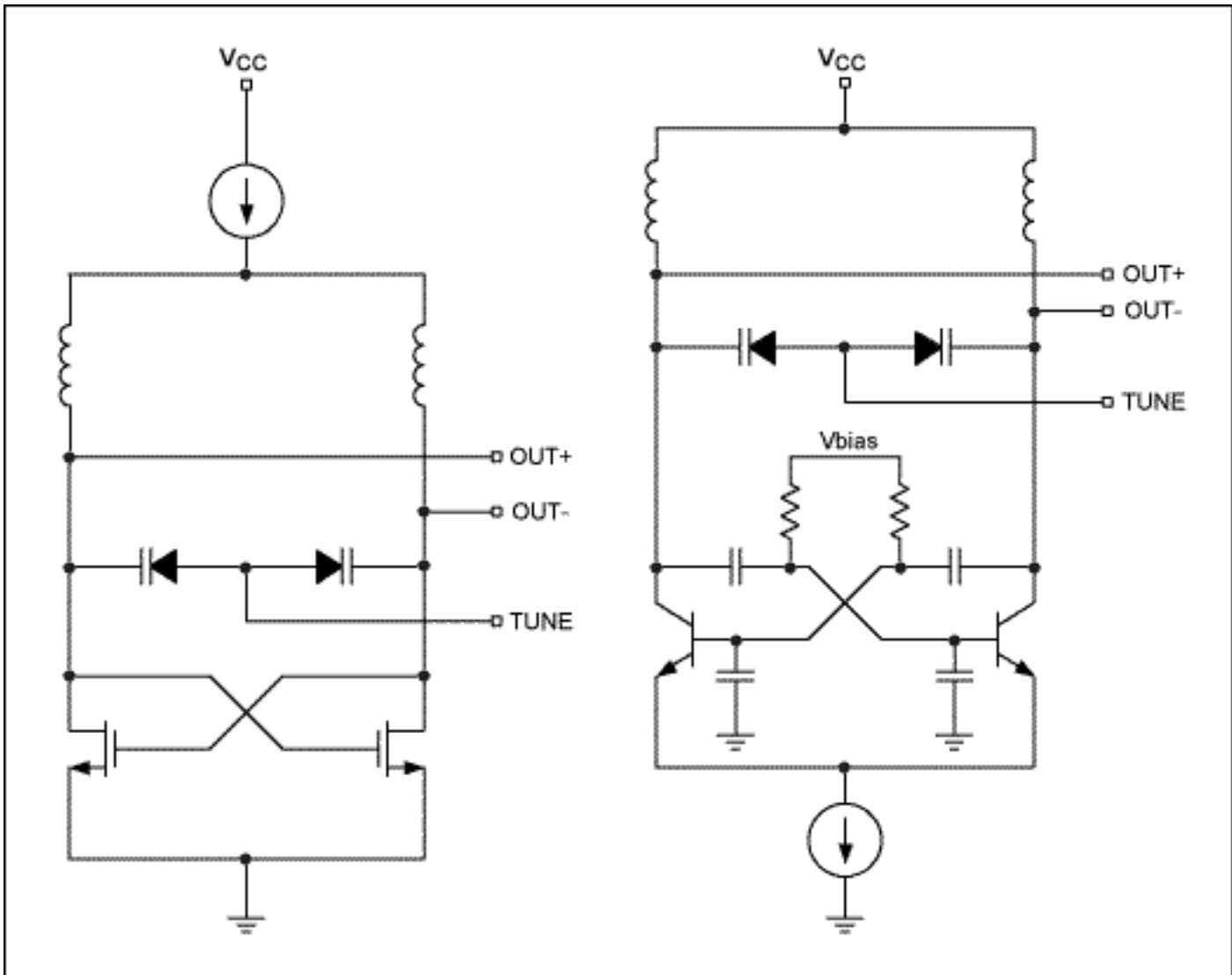

Figure 5. Typical monolithic VCO core circuit in MOS and bipolar.

Generally, the overall performance of these early VCO IC implementations was inferior to discrete implementations and VCO modules. Specifically, the phase noise and tuning characteristics were inferior to what could be routinely achieved in discrete designs or VCO modules. This shortfall was principally due to the low-Q inductors and crude varactor diodes commonly available in that generation of IC technologies.

However, monolithic VCOs proved to be extremely small, cost-effective, and available in the same process in which RF transceiver functions were being implemented. This meant that the VCO could be integrated with other RF and IF functions, such as the mixer, low-noise amplifier (LNA), and phase-locked loop (PLL). The ability to integrate the VCO cost effectively with other receiver and transmitter functions helped make the monolithic VCO IC a commercial reality. A good early example of this was a commercial 900MHz spread-spectrum cordless-telephone chipset.¹²

In the late-1990s, research on VCO IC technology intensified considerably.^{13–19} This was in large part due to the explosion in the wireless markets and to the proliferation of high-frequency bipolar, CMOS, and BiCMOS process technologies. Significant research and development occurred in both industry and academia. Researchers focused on improving the phase-noise performance, extending the frequency of operation, and adjusting the VCO's tuning range on-chip. Providing useful performance improvements, these advances achieved electrical specifications which permitted the VCOs to be used in RFICs for cordless phones, Bluetooth®, WLAN, GPS, and DBS applications. **Table 1** summarizes some commercial RFICs which contain monolithic VCOs.

Table 1. Examples of Monolithic VCOs Integrated in Commercial RFICs

Unit	Frequency Range (MHz)	Source	Application
MAX2622/23/24	855 to 998	Maxim	General purpose, 900MHz ISM
MAX2750–MAX2753	2025 to 2500	Maxim	General purpose, 2.4GHz ISM band
MAX2754	1145 to 1250	Maxim	2.4GHz cordless phones
MAX2114	925 to 2175	Maxim	DBS
MAX3580	170 to 230, 470 to 878	Maxim	DVB-T
MAX3540	54 to 100, 100 to 300, 300 to 860	Maxim	Analog/digital terrestrial receivers
MAX2900	902 to 928	Maxim	900MHz ISM band (wireless meter reading)
MAX2820	2400 to 2500	Maxim	802.11b WLAN
MAX2830	2400 to 2500	Maxim	802.11g WLAN
MAX2837	2300 to 2700	Maxim	802.16e Mobile WiMAX SM
MAX2838	3300 to 3900	Maxim	802.16e Mobile WiMAX
MAX2839	2300 to 2700	Maxim	802.11n WLAN with MIMO down link
RF105	902 to 928	Conexant™	900MHz cordless phones
SA2400	2400 to 2500	Philips	802.11b WLAN
BlueCore-01	2400 to 2500	CSR	Bluetooth
TRF	2400 to 2500	TI®	Bluetooth
GRF2i/LP	1575	SiRF	GPS
AR5111	5.2GHz to 5.8GHz	Atheros®	802.11a WLAN

These VCO ICs and the integrated solutions that contain them are smaller and more cost-effective than VCO modules. They are easier and faster to apply than discrete solutions. The monolithic VCO ICs provide significantly improved value over previous technologies.

Because the performance of this generation of VCO technology is sufficient for systems like cordless phones, wireless data radios, and DBS receivers, the technology is being widely adopted for these systems. However, the phase-noise performance is presently about 5dB to 10dB too high to meet the requirements of higher-data-rate mobile telephone systems (such as GSM, IS-136, CDMA). Low inductor Q and excess bias noise both contribute to limits for the VCO phase noise. Although some research has demonstrated promising results from the use of bond-wire inductors, low-phase-noise performance has remained elusive and out of reach for monolithic VCO IC technology. However, from 1999 through 2001 many significant advances in VCO design have been reported and suggest some promising clear trends for the future.

Major Trends

Several trends are impacting the development of monolithic VCOs with improved phase noise. For example, basic RFIC process technologies continue to improve. The advanced quality possible with semiconductor processes is increasing, and the performance of active and passive devices is improving. Even with silicon processes, transistors can now be fabricated with f_T performance that exceeds 50GHz; higher-Q varactor diodes are available with wide-capacitance ratio tuning ranges (low series resistance). These processes feature lower-loss substrates with thicker metalizations and higher-Q inductors. The processes produce devices with reduced parasitic elements, leading to VCOs with lower phase noise, higher operating frequencies, and lower current operation.

Design techniques are also advancing. VCO researchers are exploiting the power of IC technologies by devising more sophisticated circuits to improve performance. Researchers are introducing techniques previously impractical with discrete VCO or modular VCO implementations. Examples include differential oscillator topologies, amplitude control, second-harmonic traps, IC transformers for improved coupling, topologies with multiple oscillators, and architectures capable of higher frequency operation.

Design engineers are also gaining a better understanding of VCO theory. They are building upon mathematical models from the past, such as Van der Pol's and Leeson's equations. They are devising new analytic expressions for oscillator behavior (such as tuning characteristics and phase-noise performance). Circuit designers are amending Leeson's noise equations with Abidi's relationships. In addition, computer-aided-engineering (CAE) tools are growing in power and sophistication as the processing capabilities of personal and workstation computers increase. Engineers can now experiment with VCO behavioral models to discover performance enhancements.

Monolithic VCO technology continues to appear in an increasing number of new products, and high-quality VCOs are now integrated into the transceiver circuitry. For example, the latest wireless ICs for the WLAN, WiMAX, TV tuners, GPS, and Bluetooth markets integrate the VCO within the ICs, resulting in a dramatic reduction in size compared to discrete components. In higher-performance WLAN radios (2.4GHz IEEE® 802.11b and 5GHz 802.11a versions) and WiMAX radios (IEEE 802.16e Mobile WiMAX and 802.16-2004/802.16d fixed WiMAX), system requirements call for higher-performance VCOs with the very low phase noise needed to achieve the needed packet data rates and blocking performance levels.

Improvements in RFIC VCO technology make these integrated sources ever more attractive for an increasing number of commercial RF applications, including satellite receivers, CATV set-top boxes, wireless data applications, cordless telephones, and mobile cell phones. Clearly, monolithic VCOs are winning an ever-increasing share of high-volume applications compared to discrete and modular VCO solutions.

The time is coming very soon when monolithic VCOs will be the dominant oscillator approach in all high-volume commercial wireless systems. Thus, VCOs have traversed a remarkable path from bulky tube-based circuits to < 1mm square of silicon.

References

1. B.N. Scott and G.E. Brehm, *Monolithic Voltage Controlled Oscillator for X- and Ku-bands*, IEEE Trans. Microwave Theory & Tech., Vol. MTT-30, No. 12, December 1982, pp. 2172-2177.
2. B.N. Scott, M. Wurtele, and B.B. Cregger, *A Family of Four Monolithic VCO MIC's Covering 2-18GHz*, Monolithic Circuits Symposium Digest, 1984, pp. 54-61.
3. N.M Nguyen and R.G Meyer, *A 1.8GHz Monolithic LC Voltage-Controlled Oscillator*, IEEE JSSC, Vol. 27, March 1992, pp. 444-450.
4. P. Basedau and Q. Huang, *A 1GHz, 1.5V Monolithic LC Oscillator in 1um CMOS* in Proc. of 1994 European Solid State Circuits Conference; Ulm, Germany, Sept. 1994, pp. 172-175.
5. J. Craninckx and M. Steyaert, *Low-Noise Voltage Controlled Oscillators Using Enhanced LC-tanks*, IEEE Trans. Circuits and Sys. -II, Vol. 42, Dec. 1995, pp. 794-804.
6. M. Soyuer, K.A. Jenkins, J.N. Burghartz, and M. D. Hulvey. *A 3V 4GHz nMOS Voltage-Controlled*

- Oscillator With Integrated Resonator*. IEEEJ. Solid State Circuits. Vol.31, Dec. 1996, pp.388-389.
7. B. Razavi, *A 1.8GHz CMOS Voltage-Controlled Oscillator*, ISSCC Dig. Tech. Papers, 1997. pp.390-391.
 8. See reference 9.
 9. L. Dauphinee, M. Copeland, and P. Schvan. *A Balanced 1.5GHz Voltage-Controlled Oscillator With an Integrated LC Resonator*, ISSCC Dig. Tech Papers, 1997, pp.390-391.
 10. A. Ali and J.L. Tham. *A 900MHz Frequency Synthesizer With Integrated LC Voltage-Controlled Oscillator*, ISSCC Dig. Tech. Papers, 1996, pp. 390-391.
 11. B. Jansen, K. Negus, and D. Lee, *Silicon Bipolar VCO Family For 1.1-2.2GHz With Fully Integrated Tank and Tuning Circuits*, ISSCC Dig. Tech Papers, 1997, pp. 392-393.
 12. M. Zannoth, B. Kolb, J. Fenk, and R. Weigel. *A Fully Integrated VCO at 2GHz*. IEEEJ. Solid-State Circuits, Vol.33, Dec. 1998, pp. 1987-1991.
 13. P. Kinget, *A Fully Integrated 2.7V 0.35um CMOS VCO for 5GHz Wireless Applications*, ISSCC Dig. Tech. Papers, 1998. pp.226-227.
 14. T. Liu, *A 6.5GHz Monolithic CMOS Voltage-Controlled Oscillator*, ISSCC Dig. Tech. Papers, 1999, pp. 401-405.
 15. C. Lam and B. Razavi. *A 2.6GHz/5.2GHz CMOS Voltage Controlled Oscillator*, ISSCC Dig. Tech. Papers, 1999, pp. 402-403.
 16. D.B. Leeson, *A Simple Model of Feedback Oscillator Noise Spectrum*, Proceedings of the IEEE, Vol. 54, Feb. 1966, pp. 329-330.
 17. A. Hajimiri and T. Lee, *A General Theory of Phase Noise in Electrical Oscillators*, IEEE JSSC, Vol. 33 no. 2, Feb. 1998, pp.179-194.
 18. A. Hajimiri and T. Lee, *Design Issues in CMOS Differential LC Oscillators*, IEEE JSSC, May 1999.
 19. C. Hung and K. O. Kenneth, *A Packaged 1.1GHz CMOS VCO With Phase Noise of -126dBc/Hz at a 600KHz Offset*, IEEEJ. Solid-States Circuits, Vol.35, Jan. 2000, pp. 100-103.

* The heterodyne principle is defined as the multiplication of two signals in the time domain to produce a frequency shift in the frequency domain. The principle is the fundamental basis for frequency translation of signals in wireless systems.

** Both Edwin Armstrong and Lee DeForest were working on regenerative receiver circuits at the time. These regenerative circuits created the first oscillators.

A similar version of this article appeared in the July 2002 issue of *Microwave and RF* magazine.

Atheros is a registered trademark of Atheros Communications, Inc.

Bluetooth is a registered trademark of Bluetooth Sig, Inc.

Conexant is a trademark of Conexant Systems, Inc.

IEEE is a registered service mark of the Institute of Electrical and Electronics Engineers.

TI is a registered trademark of Texas Instruments Incorporated.

WiMAX is a trademark of the WiMAX Forum.

Application Note 1768: www.maxim-ic.com/an1768

More Information

For technical support: www.maxim-ic.com/support

For samples: www.maxim-ic.com/samples

Other questions and comments: www.maxim-ic.com/contact

Automatic Updates

Would you like to be automatically notified when new application notes are published in your areas of interest?

[Sign up for EE-Mail™.](#)

Related Parts

MAX2622: [QuickView](#) -- [Full \(PDF\) Data Sheet](#) -- [Free Samples](#)

MAX2624: [QuickView](#) -- [Full \(PDF\) Data Sheet](#) -- [Free Samples](#)

MAX2750: [QuickView](#) -- [Full \(PDF\) Data Sheet](#) -- [Free Samples](#)

MAX2753: [QuickView](#) -- [Full \(PDF\) Data Sheet](#)

MAX2754: [QuickView](#) -- [Full \(PDF\) Data Sheet](#) -- [Free Samples](#)

MAX2820: [QuickView](#) -- [Full \(PDF\) Data Sheet](#) -- [Free Samples](#)

MAX2900: [QuickView](#) -- [Full \(PDF\) Data Sheet](#) -- [Free Samples](#)

AN1768, AN 1768, APP1768, Appnote1768, Appnote 1768

Copyright © by Maxim Integrated Products

Additional legal notices: www.maxim-ic.com/legal