

APPLICATION NOTE 1101

IR Sensor/Monitor Wakes Host System

Abstract: The combination of an ultra low supply current, comparator plus reference (MAX971) and photodiode are used to detect infrared (IrDA) signals for TV remote control, etc. RC filters reduce ambient light noise and AC mains hum. The circuit's output can drive a CMOS set-reset flip-flop or interrupt a sleeping microprocessor.

The sensor/monitor circuit of **Figure 1** "wakes up" the host system on detection of infrared (IR) signals. It draws so little supply current that it can remain continuously on in a notebook computer or PDA device. Its ultra-low current drain ($4\mu\text{A}$ maximum, $2.5\mu\text{A}$ typical) is primarily that of the comparator/reference device IC1.

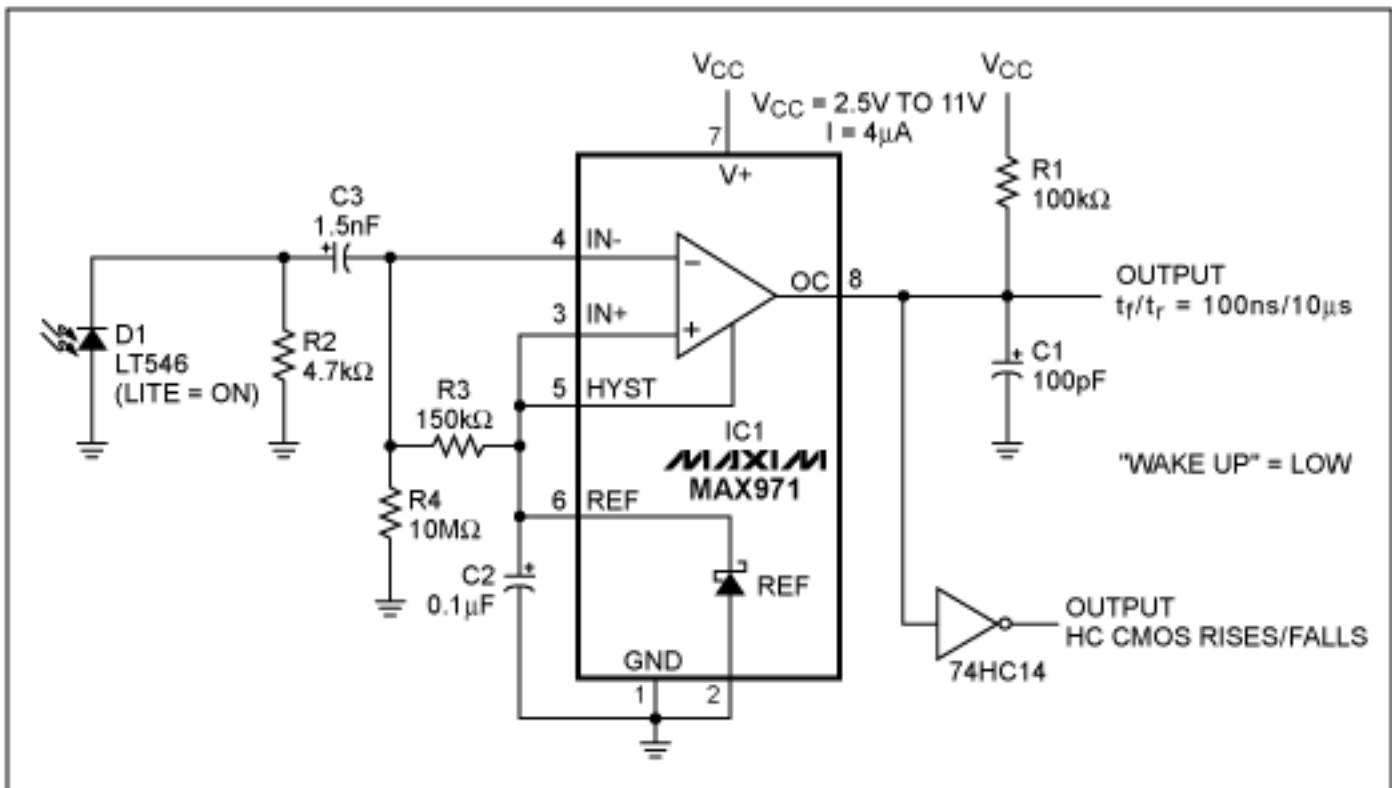

Figure 1. This low-quiescent-current circuit ($4\mu\text{A}$ maximum) interrupts the host processor when it detects an IR signal.

The circuit is intended for the noncarrier systems common in Infrared Data Association (IrDA) applications. It also operates with carrier protocols such as those of TV remote controllers and Newton/Sharp ASK (an Amplitude Shift Keying protocol developed by Sharp and used in the Apple Newton). The range for 115,000-baud IrDA is limited to about 6 inches, but for 2400-baud IrDA it improves to more than 1 foot.

Immunity to ambient light is very good, although bright flashes usually cause false triggers. To handle occasional false triggers, the system simply looks for IR activity after waking and then returns to sleep mode if none is present.

The sensor shown (D1), a relatively large-area photodiode packaged in an IR-filter material, produces about $60\mu\text{A}$ when exposed to heavy illumination (and 0.4V when open-circuited). Most such photodiodes are acceptable in this circuit. Operation is in the photovoltaic mode (without applied bias). This mode is slow and not generally used in photodiode circuits, but speed is not essential here. The photovoltaic mode simplifies the circuit and

saves a significant amount of power. In a more conventional configuration (i.e., photoconductive), photo currents caused by ambient light and sourced by the bias network would increase the quiescent current approximately ten times.

V_{REF} and the R3/R4 divider introduce an 18mV bias between the comparator inputs. Derived from the reference, this bias is independent of the supply voltage. To suppress 60Hz/120Hz hum and other low-frequency disturbances, C3 and the R3/R4 divider form a highpass network with a cutoff frequency of 700Hz. C3 is normally charged to V_{REF} minus the 18mV bias, and any voltage produced by photocurrent through R2 adds to the voltage on C3.

Thus, any IR signal across R2 that exceeds the 18mV threshold trips the comparator and causes its output to go low (18mV represents a good tradeoff between range, noise immunity, and DC stability.) The low value of R2 prevents saturation of the photodiode in ambient light. If saturation is an issue, the R2 value can be reduced further-with a penalty in sensitivity and a boost in speed.

The comparator's input offset voltage (10mV maximum) sets worst-case extremes of 6mV and 28mV for the IR trip threshold, but this spread is not a significant issue. Typical spreads are much smaller than the maximums, and typical IR signals generate more than 60mV. A variation in offset affects the amount of overdrive, and therefore affects only the comparator's response speed.

The circuit's output can trip a set-reset flip-flop or interrupt a sleeping processor. The optional HCMOS gate (preferably a Schmitt-trigger type) can improve the output rise/fall times with very little effect on the overall quiescent current.

A similar idea appeared in the October 13, 1997 issue of *Electronic Design*.

Application Note 1101: <http://www.maxim-ic.com/an1101>

More Information

For technical questions and support: <http://www.maxim-ic.com/support>

For samples: <http://www.maxim-ic.com/samples>

Other questions and comments: <http://www.maxim-ic.com/contact>

Related Parts

MAX971: [QuickView](#) -- [Full \(PDF\) Data Sheet](#) -- [Free Samples](#)

AN1101, AN 1101, APP1101, Appnote1101, Appnote 1101

Copyright © by Maxim Integrated Products

Additional legal notices: <http://www.maxim-ic.com/legal>