

APPLICATION NOTE 1050

Reset Circuit Ensures Valid Supply Voltage

Abstract: This article focuses on using an external MOSFET switch to ensure a valid system voltage is present before applying it to the load. This simple circuit uses a reset circuit and the MOSFET to provide a protection circuit during power-up.

It is often necessary to prevent a power supply's voltage from being applied to a load until the voltage has reached a certain minimum value. The circuit of **Figure 1**, consisting of two compact SOT23 packages, protects the load by blocking the supply voltage (nominally 5V) when it is below a pre-set threshold. IC1's threshold is 4.63V; four other versions of this IC provide thresholds of 4.38V, 3.08V, 2.93V, and 2.63V.

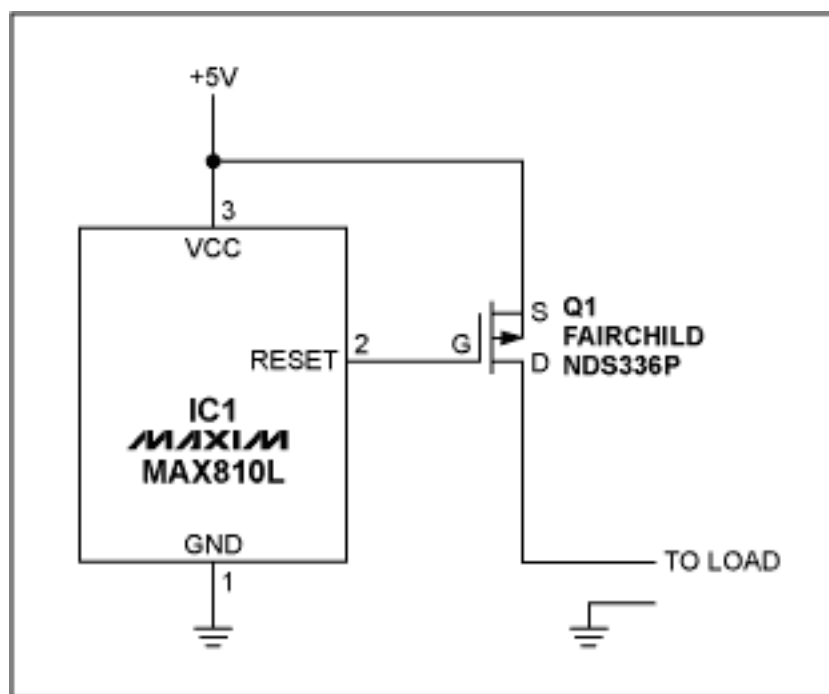

Figure 1. This protection circuit applies power to the load only when V_{CC} is above a pre-set threshold voltage.

IC1's active-high Reset output holds the p-channel MOSFET off by remaining high during power-up. It continues to remain high through the end of the reset timeout period (140ms minimum), which is initiated by IC1 as V_{CC} passes through the 4.63V threshold. If V_{CC} remains above 4.63V after the timeout has expired, Reset goes low, turns on Q1, and applies V_{CC} to the load. Q1's on-resistance (0.2Ω for $V_{GS} = 4.5V$) can deliver 1A of supply current with a drop of only 200mV.

If V_{CC} falters and drops below the threshold during the timeout, or if V_{CC} dips below threshold during normal operation, Q1 turns off and removes V_{CC} from the load. During power-down as well, Reset goes high and turns Q1 off as soon as V_{CC} drops below the threshold. IC1 maintains this gate drive for V_{CC} down to 1V; below that level, the load remains safe because V_{GS} is too low to turn Q1 back on.

This circuit can be implemented with any microprocessor-reset device offering an active-high, push-pull reset output. As alternatives offering other threshold levels and feature combinations, consider the MAX812, MAX824,

MAX6327, and MAX6332.

Application Note 1050: <http://www.maxim-ic.com/an1050>

More Information

For technical questions and support: <http://www.maxim-ic.com/support>

For samples: <http://www.maxim-ic.com/samples>

Other questions and comments: <http://www.maxim-ic.com/contact>

Related Parts

MAX6327: [QuickView](#) -- [Full \(PDF\) Data Sheet](#) -- [Free Samples](#)

MAX6332: [QuickView](#) -- [Full \(PDF\) Data Sheet](#) -- [Free Samples](#)

MAX812: [QuickView](#) -- [Full \(PDF\) Data Sheet](#)

MAX824: [QuickView](#) -- [Full \(PDF\) Data Sheet](#)

AN1050, AN 1050, APP1050, Appnote1050, Appnote 1050

Copyright © by Maxim Integrated Products

Additional legal notices: <http://www.maxim-ic.com/legal>